

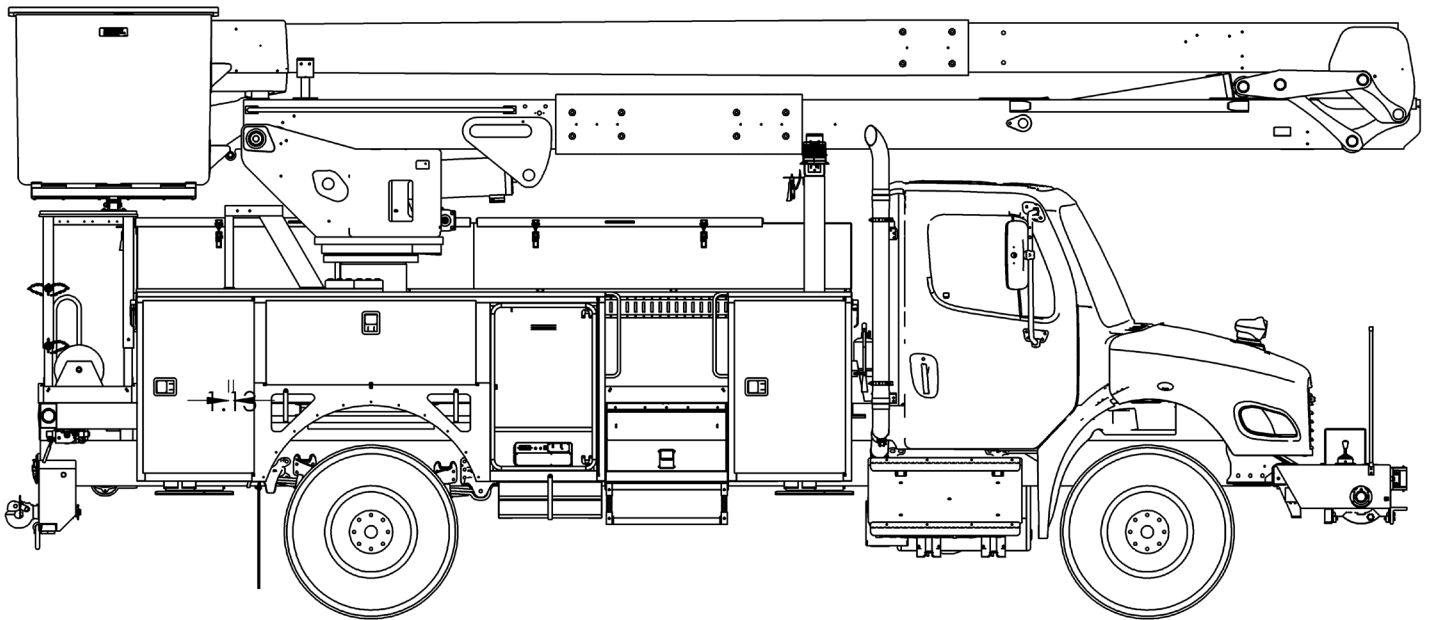

# TECH TIPS

CANVIEW 4 SWITCH PANEL FEATURES AND TROUBLESHOOTING

NO. 108



**SERVICE CALL:**  
CANVIEW 4 SWITCH  
PANEL FEATURES AND  
TROUBLESHOOTING



**MODEL(S):**  
ALL TEREX UTILITIES EQUIPMENT  
USING THE CANVIEW 4 SWITCH  
PANEL



**TOOLS NEEDED:**  
NONE

TEREX UTILITIES TECHNICAL SUPPORT TEAM

PHONE: 1-844-TEREX4U (1-844-837-3948) | EMAIL: [UTILITIES.SERVICE@TEREX.COM](mailto:UTILITIES.SERVICE@TEREX.COM)



## **DANGER**

Failure to obey the instructions and safety rules in the appropriate Operator's Manual and Service Manual for your machine will result in death or serious injury.

Many of the hazards identified in the Operator's Manual are also safety hazards when maintenance and repair procedures are performed.

## **DO NOT PERFORM MAINTENANCE UNLESS:**

- ✓ You are trained and qualified to perform maintenance on this machine.
- ✓ You read, understand and obey:
  - manufacturer's instructions and safety rules
  - employer's safety rules and worksite regulations
  - applicable governmental regulations
- ✓ You have the appropriate tools, lifting equipment and a suitable workshop.

The information contained in this Tech Tip is a supplement to the Service Manual. Consult the appropriate Service Manual of your machine for safety rules and hazards.



TECH TIP 108 | RELEASED 12.07.2023 | VERSION 1.0  
©TEREX UTILITIES. ALL RIGHTS RESERVED

# CONTENTS

## TECH TIP #108

### TOC

4

| *Canview 4 System*

**INTRODUCTION**  
**STEP 1 - STEP 2**

5

| *Troubleshooting codes*

| *Diagnostic screen*

**STEP 3 - STEP 4**

6

| *Inputs and Outputs*

**STEP 5 - STEP 8**

7

| *System Test*

**STEP 9**

8

| *Event Log*

**STEP 10**

9

| *Usage meters*

**STEP 11**

10

| *Model Code*

**STEP 12**

## INTRODUCTION

This tech tip is an overview of the system to help illustrate the features and to demonstrate programming the unit.

Note: Not all units have programming capability. Contact Terex Utilities Technical Support at 1-844-Terex4U (1-844-837-3948) or [utilities.service@terex.com](mailto:utilities.service@terex.com) with any questions.



## STEP 1





Terex has introduced its new Canview 4 Switch Panel. The switch panel consists of:

- 5 soft touch buttons with an indicator directly above each button
- Switches are momentary, programmed to latch outputs ON / OFF
- Display screens show truck information and user warnings such as PTO Hours, Outrigger Sag, Diagnostic Screens, etc.
- The switch panel communicates with the Chassis Controller using the J1939 Datalink connection

## STEP 2

The indicators on the main screen are shown in the image below. Only the indicators associated with the unit set-up will be shown. LED indicators are used when something is active on another screen.







-  Icon for AUX pump, grey if Off, Orange if on.
-  Demand Icon, Grey if off, Green if available, Red if disabled
-  Radio Icon, grey if off, orange if radio throttle is active
-  Tools icon, Grey if off, orange if on.
-  Hydraulic oil high temp Icon. Red if hydraulic temp input is active. else it is hidden

### STEP 3

The Canview 4 setup has a PTO display indicator to assist with troubleshooting. When the PTO is turned on it will be green unless there is a fault.

The chart below lists the colors along with the troubleshooting codes.



-  Off
-  On – no PTO output
-  On – PTO output is on, no pressure switch off
-  On – PTO output is on, with pressure switch on
-  On – PTO output is off, with pressure switch on

### STEP 4

To access the diagnostic screen on the new panel press and release the center button (Home/ Select). Then press the button marked Diag. to bring up the diagnostics page.

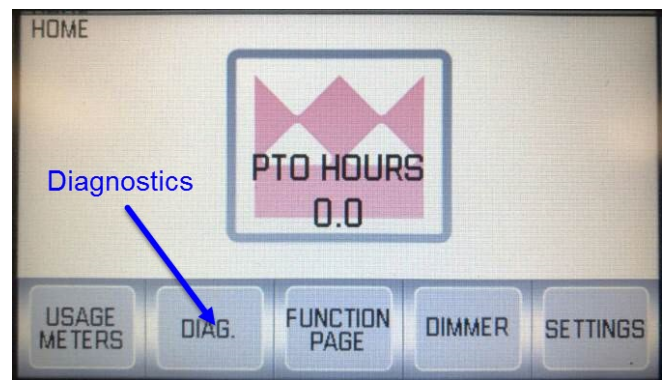

## STEP 5

Once on the Diagnostic screen page. Button function for Inputs, Outputs, Status, and Next will be shown. The Next function toggles between pages 1 and 2 of the selected inputs or outputs page.

Inputs/outputs will have 3 conditions: ON, OFF or FAULT. FAULT will either be an overload or a short circuit.



## STEP 6

Click on the Inputs button to see which inputs are ON or OFF.

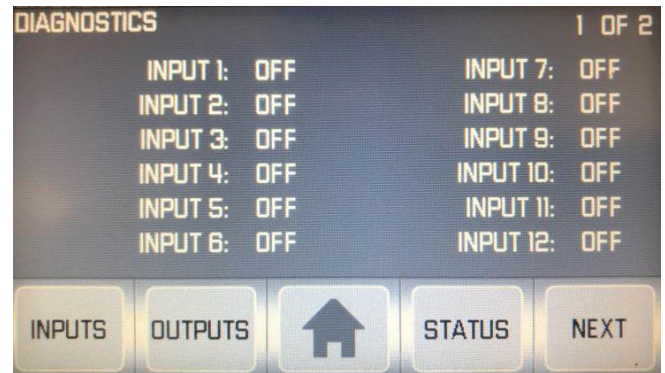

## STEP 7

Click on the Outputs button to see which outputs are OFF, ON, or FAULT. Faults are typically caused by a short.

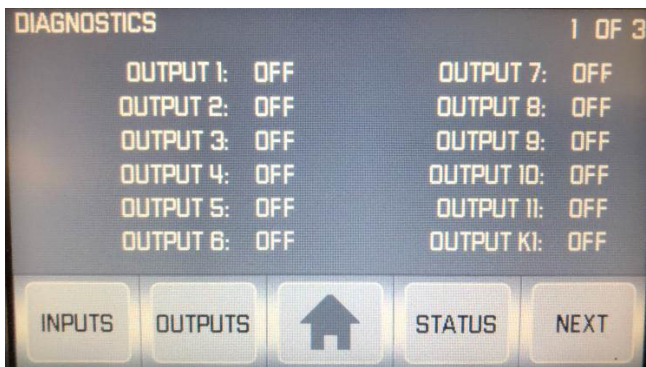

## STEP 8

The Status screen provides information on the CAN wiring. If FAULT is shown for controller stat, check the wiring and connections for the CAN network.

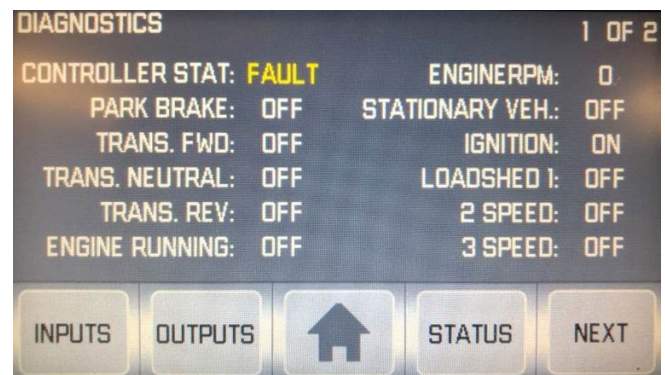

## STEP 9

A system test can be performed to walk through most system operations. The Next button will appear when each step is complete; the Prev button will go back and repeat the step.

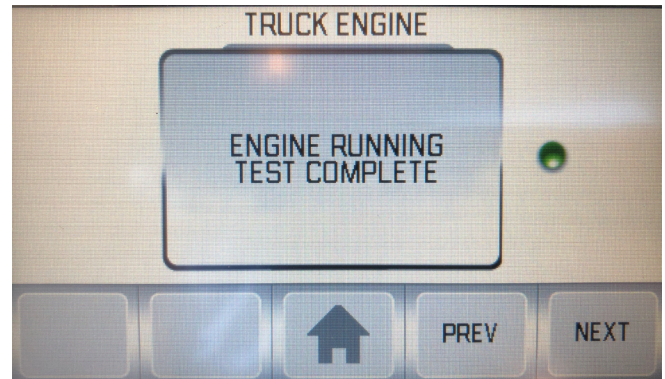

During some steps, a function button will appear on Button 1. This button will perform a walk-through of multiple functions such as: checking the park brake, making sure the engine is running, verifying the PTO, start/stop, throttle and light operations.

In the example below, the PTO function is verified.



## STEP 10

Another troubleshooting feature that is available is the Event Log. The log displays the events stored in memory as well as how many times each event has occurred.

To get to the event log from the functions page, click the Home/Select button in the middle of the screen.



Then click the button for Settings.



In Settings, scroll through the options until Event Log is visible.

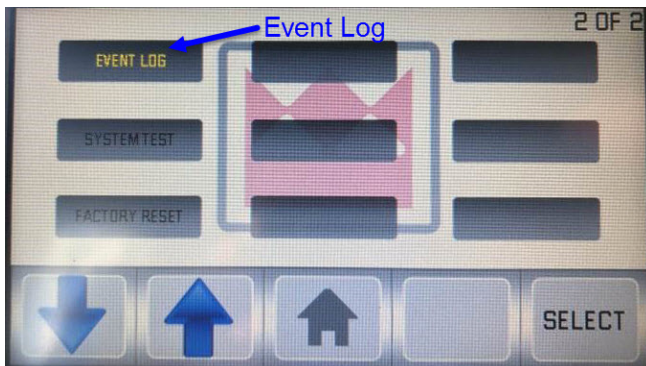

In Settings, scroll through the options until Event Log is visible.

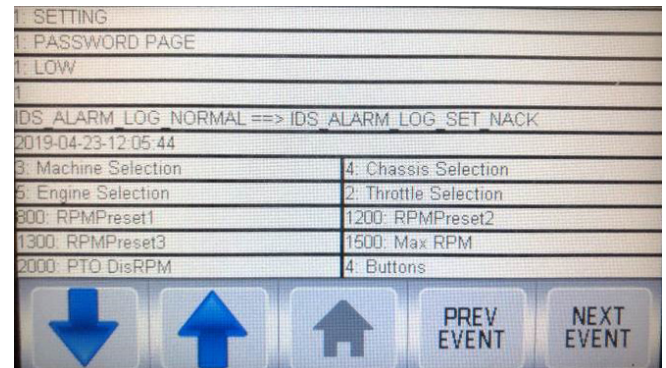



To download the Event Log, install an empty flash drive onto the USB connector located on the switch panel wiring harness.

Press and hold the first button on the switch panel (Down Arrow) until it disappears. When the down arrow disappears, the file is saved onto the flash drive.

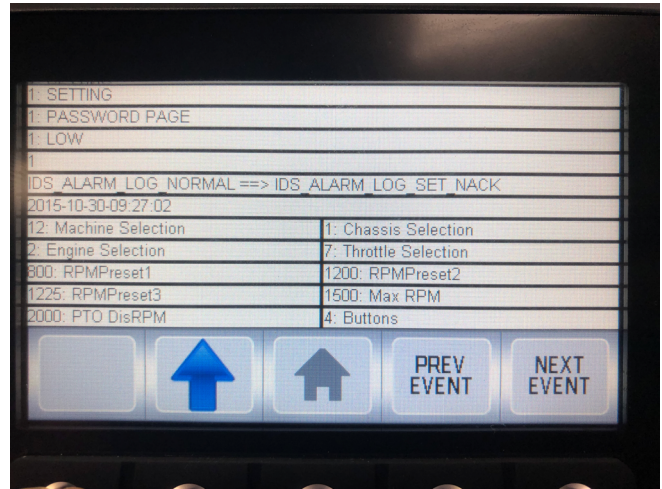

Name	Date modified
 eI0_at_CANVIEW4_23092019_155307	10/7/2019 2:34 PM

## STEP 11

Canview 4 has usage meters built into the program which may be used to track: PTO hours, boom usage hours, hydraulic usage hours, boom non-stow and idle hours. Pushing the Log button will store the information in the event log.



## STEP 12

Each unit that is using the Canview4 system will have a Model Code. This code is important when replacing the switch panel for any reason to reduce the amount of time needed to program the new switch panel. To find your model code hit the home select button.



Click the button for settings



In Settings, scroll through the options until Model code is visible. Click select.

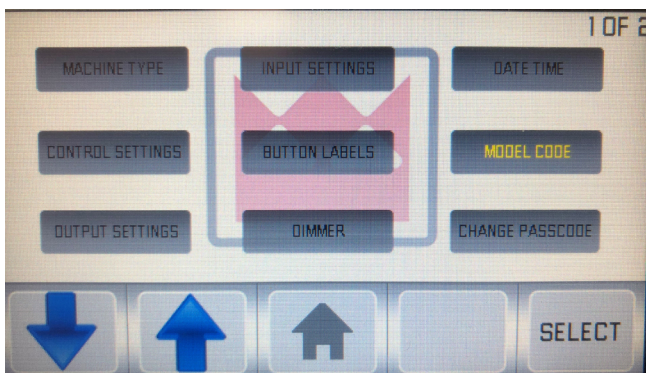

Click select to view the model code below.

Record the model code either in the manual or maintenance records for the unit in case the switch panel needs to be replaced in the future.

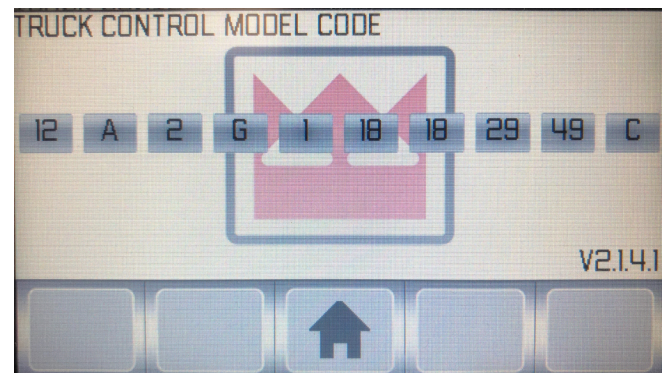



FOR FURTHER ASSISTANCE,  
CONTACT THE TEREX UTILITIES TECHNICAL SUPPORT TEAM  
PHONE: [1-844-TEREX4U \(1-844-837-3948\)](tel:1-844-TEREX4U) | EMAIL: [UTILITIES.SERVICE@TEREX.COM](mailto:UTILITIES.SERVICE@TEREX.COM)

---