

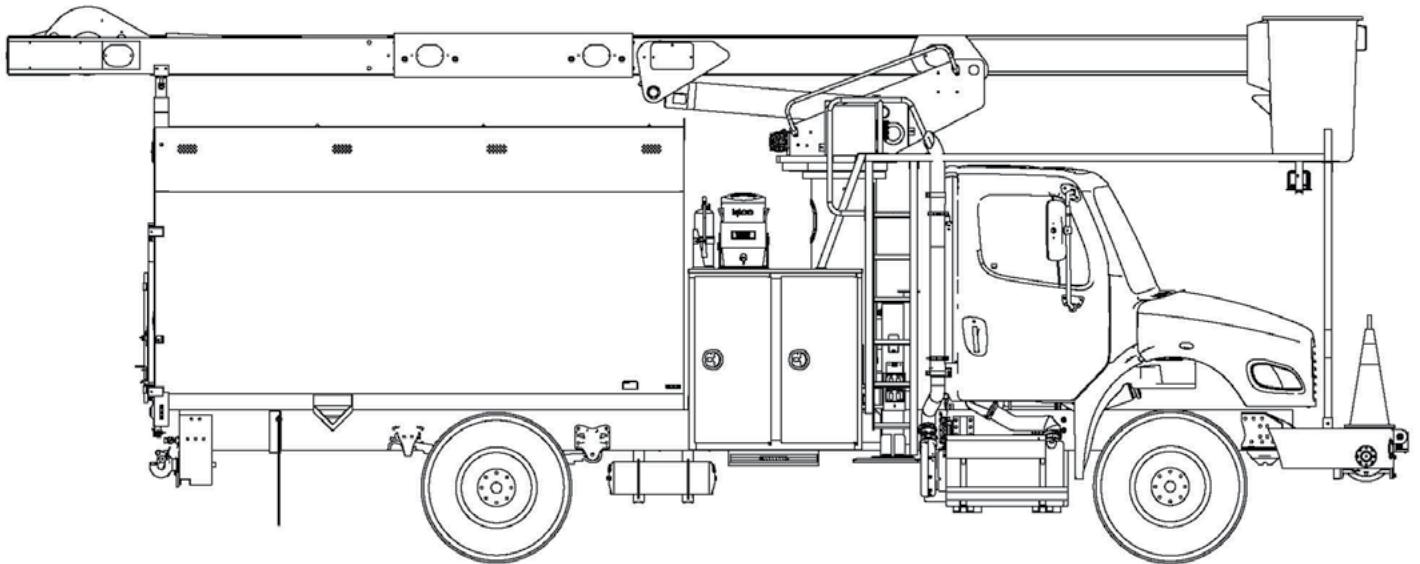

TECH TIPS

PERFORMING A FLOW TEST ON A PUMP

NO. 109



SERVICE CALL:
PERFORMING A FLOW TEST ON
A PUMP



MODEL(S):
ALL TEREX UTILITIES MODELS
WITH A VANE OR GEAR PUMP



TOOLS NEEDED:
BASIC HAND TOOLS
CALIBRATED FLOW METER
RATED FOR THE PROPER FLOW
OIL DRAIN PAN

TEREX UTILITIES TECHNICAL SUPPORT TEAM

PHONE: 1-844-TEREX4U (1-844-837-3948) | EMAIL: UTILITIES.SERVICE@TEREX.COM

! WARNING



Injection Hazard
Fluid escaping under pressure can penetrate skin and result in death or serious injury.



Relieve pressure before disconnecting hydraulic lines.
Stay clear of leaks and pin holes. Use a piece of cardboard or wood to search for leaks. Do not use hand.
Fluid injected into skin must be surgically removed within a few hours by a doctor familiar with this type of injury, or gangrene will result.



DANGER

Failure to obey the instructions and safety rules in the appropriate Operator's Manual and Service Manual for your machine will result in death or serious injury.

Many of the hazards identified in the Operator's Manual are also safety hazards when maintenance and repair procedures are performed.

DO NOT PERFORM MAINTENANCE UNLESS:

- ✓ You are trained and qualified to perform maintenance on this machine.
- ✓ You read, understand and obey:
 - manufacturer's instructions and safety rules
 - employer's safety rules and worksite regulations
 - applicable governmental regulations
- ✓ You have the appropriate tools, lifting equipment and a suitable workshop.

The information contained in this Tech Tip is a supplement to the Service Manual. Consult the appropriate Service Manual of your machine for safety rules and hazards.



TECH TIP 109 | RELEASED 04.20.2023 | VERSION 1.0

©TEREX UTILITIES. ALL RIGHTS RESERVED

CONTENTS

TECH TIP #109

TOC

4

| *Ckise the gate valve*

| *Remove plug*

INTRODUCTION
STEP 1 - STEP 3

5

| *Determine where to install the flow meter*

STEP 4

6

| *Install the flow meter*

| *Reinstall the plug*

| *Open the gate valve*

STEP 5 - STEP 8

7

| *Start the engine and bring fluid to operating temp*

| *Slowly turn the shut-off valve*

STEP 9 - STEP 11

INTRODUCTION

A flow test is performed on a pump to determine if it has the proper flow to operate the boom efficiently.

All Terex models have a specific Gallons per Minute (GPM) requirement needed for the boom to operate efficiently. Check the Quick Reference guide in the unit specific manual to determine the correct flow for the specific unit.

There are many different types and sizes of flow meters. A proper flow meter will consist of a calibrated meter, calibrated pressure gauge, and a manual shut-off.

Make sure the flow meter can handle the maximum output flow and pressure of the machine to be tested.

Pressures and flows can be found in the Quick Reference section of the unit specific maintenance manual

STEP 1

Make sure the unit is turned OFF and positioned in a suitable location.

STEP 2

Close the gate valve(s) on the suction line and the return line (if installed).



STEP 3

There may be a plug located on the return filter housing. Remove this plug to allow air into the return line to prevent syphoning

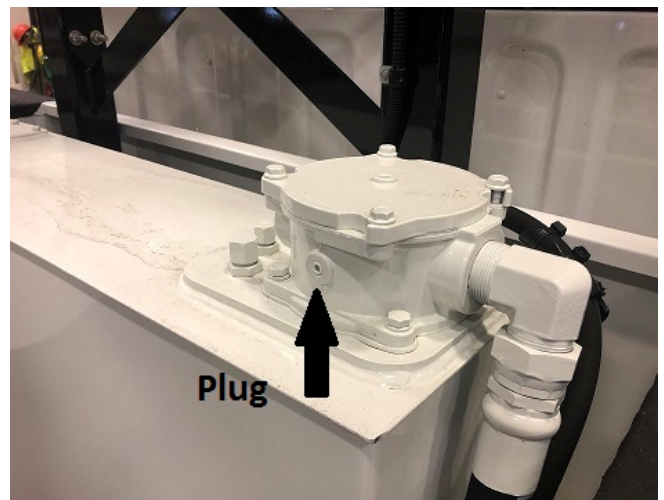

STEP 4

Determine where in the system the flow meter should be installed.

On a Digger/Derrick it could be installed to test either section of the pump.

- Small section or back section for the operation functions
- Large section or the front section for the digger/winch functions

On an Aerial there is typically only one section of a pump unless the unit is built with an Option (front bumper winch) that requires more oil than a single section pump can put out.

Check Unit specific folder to see what pump the unit was built with. Or contact Terex Technical Support for assistance at 1-844-837-3948 (1-844-Terex4U) or utilities.service@terex.com.

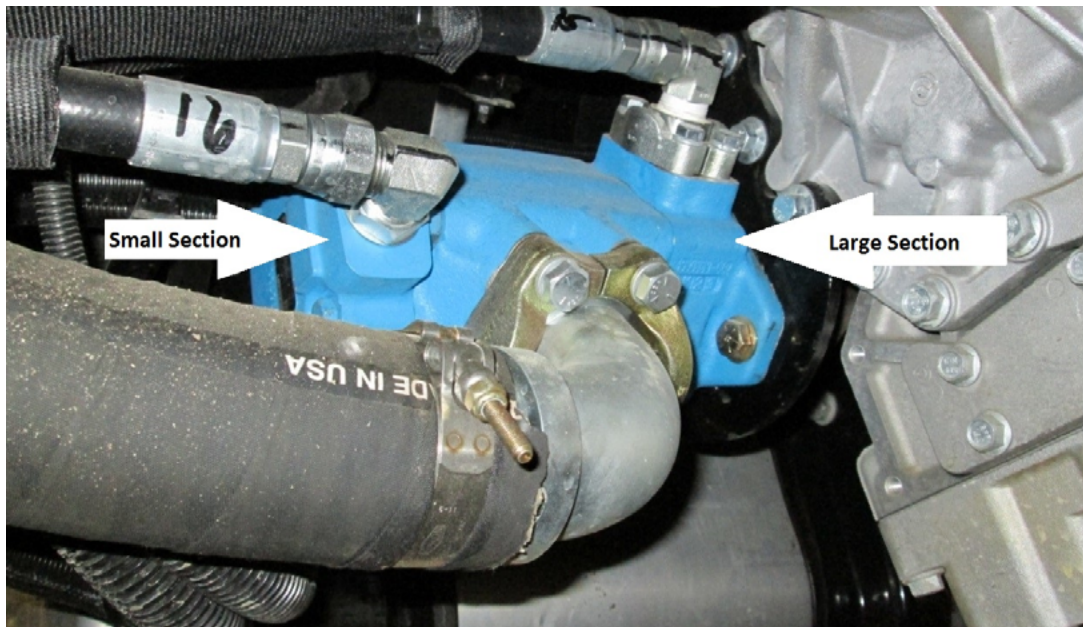

Escaping fluid under pressure can penetrate skin causing serious injury.

Relieve pressure before disconnecting hydraulic lines. Keep away from leaks and pin holes. Use a piece of cardboard or paper to search for leaks. DO NOT use your hand.

STEP 5

Install the flow meter in the pressure line off the pump. Make sure the shut off on the Flow meter is all the way open.

If the flow meter is installed before the relief cartridge, DO NOT exceed the system pressure setting to avoid damage to the pump.

STEP 6

No matter where it is installed, make sure the flow meter is installed properly so the flow in the meter is going in the right direction. The flow meter will have an inlet and outlet that are labeled.



STEP 7

Reinstall the plug in the filter housing.

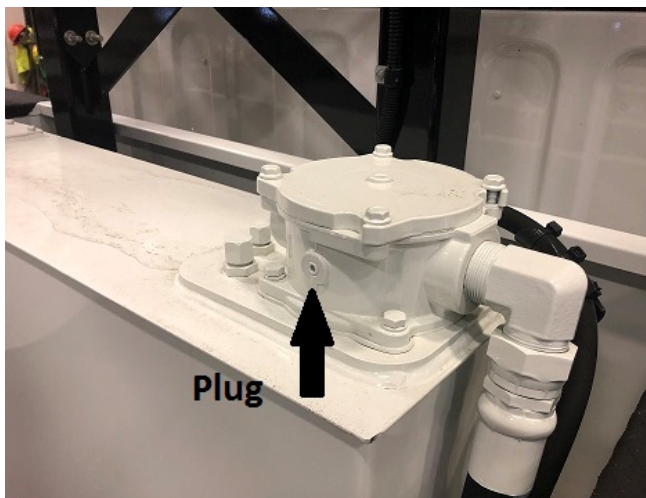

STEP 8

Make sure the gate valve(s) are secured in the open position.



Before operating the unit open the shut off valves and plug any ports removed. Failure to open shut off valves can damage the pump or blow the pump or hoses.

STEP 9

Start the engine and engage the PTO. Activate the 2-speed (if equipped).

STEP 10

Operate unit to bring the hydraulic fluid to normal operating temperature.

STEP 11

Slowly turn the shut-off valve on the flow meter in the off position to increase the back pressure. The pressure gauge on the flow meter will start to rise and the flow may start to drop.

If the flow drops dramatically before the pressure gauge reads close to system pressure, it could mean the pump is faulty and should be replaced.

If the flow meter is installed after the relief cartridge and the flow drops dramatically it could mean the pump could be faulty or that the relief cartridge is weak or improperly set. A gauge should be installed to verify that system pressure is set properly.



Do not completely close the shut off valve on the flow meter if the flow meter is installed directly after a pump without a relief valve. If the shut off valve is closed, damage to the pump will occur.

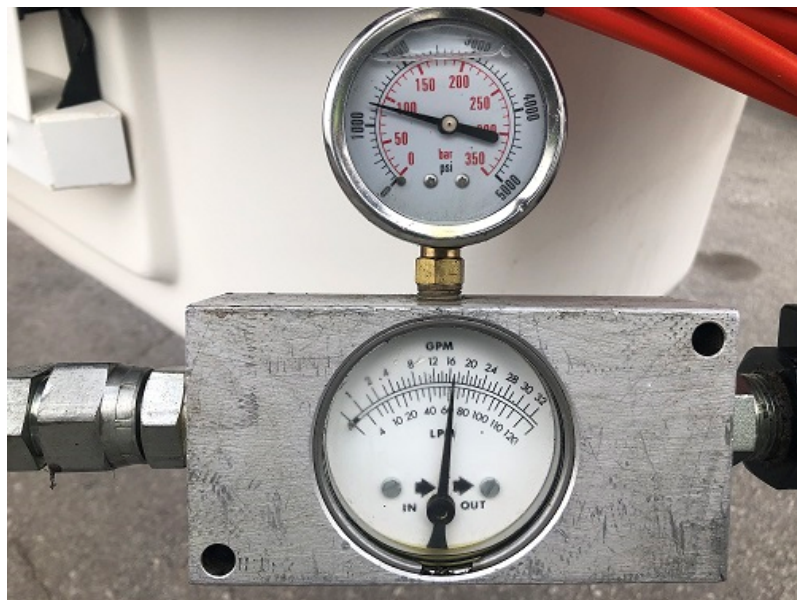

STEP 11 (Continued)

Example: Using the information below, an XT Pro should have 5 GPM at idle and 8 GPM with 2-speed activated.

PRESSURES/FLOWS

Flow at idle	5 GPM (19 LPM)
Hydraulic tool pressure.....	2250 +/- 25 PSI @ 5 GPM
.....	(15.51 +/- .17 MPa) @ (19 LPM)
Rotation port relief	2000 +/- 50 PSI (13.79 +/- .34 MPa)
System pressure	2750 +/- 50 PSI @ 8 GPM
.....	(18.96 +/- .34 MPa) @ (30 LPM)

With the 2-speed activated the flow meter should read 8 GPM with a low reading on the pressure gauge. When the shut off valve is turned in the closed direction the pressure gauge should start to rise. When the gauge reads close to 2750 psi the flow meter still should read 8 GPM.



FOR FURTHER ASSISTANCE,
CONTACT THE TEREX UTILITIES TECHNICAL SUPPORT TEAM
PHONE: **1-844-TEREX4U (1-844-837-3948)** | EMAIL: [**UTILITIES.SERVICE@TEREX.COM**](mailto:UTILITIES.SERVICE@TEREX.COM)
