

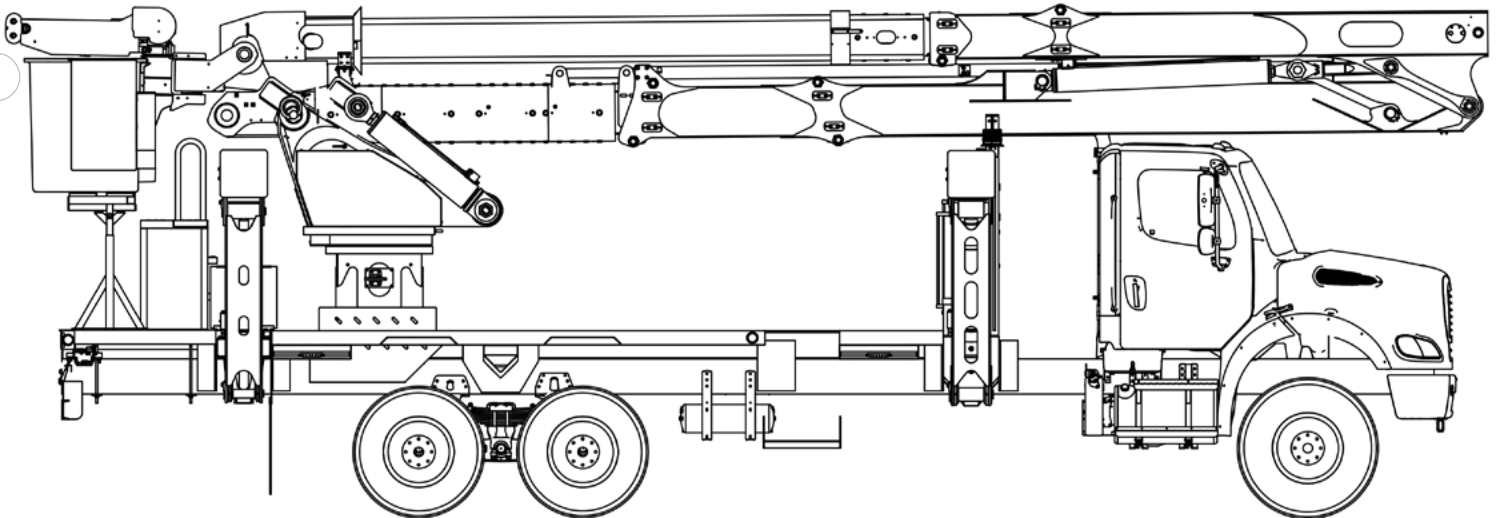

TECH TIPS

ADJUSTMENTS FOR RADIAL OUTRIGGERS CREEPING DOWN

NO. 115



SERVICE CALL:
ADJUSTMENTS FOR RADIAL
OUTRIGGERS CREEPING DOWN



MODEL(S):
ALL TEREX MODELS USING THE
CYLINDER 603020 ON RADIAL
OUTRIGGERS



TOOLS NEEDED:
SIMPLE HAND TOOLS

TEREX UTILITIES TECHNICAL SUPPORT TEAM

PHONE: 1-844-TEREX4U (1-844-837-3948) | EMAIL: UTILITIES.SERVICE@TEREX.COM



DANGER

Failure to obey the instructions and safety rules in the appropriate Operator's Manual and Service Manual for your machine will result in death or serious injury.

Many of the hazards identified in the Operator's Manual are also safety hazards when maintenance and repair procedures are performed.

DO NOT PERFORM MAINTENANCE UNLESS:

- ✓ You are trained and qualified to perform maintenance on this machine.
- ✓ You read, understand and obey:
 - manufacturer's instructions and safety rules
 - employer's safety rules and worksite regulations
 - applicable governmental regulations
- ✓ You have the appropriate tools, lifting equipment and a suitable workshop.

The information contained in this Tech Tip is a supplement to the Service Manual. Consult the appropriate Service Manual of your machine for safety rules and hazards.



TECH TIP 115 | RELEASED 04.21.2023 | VERSION 1.0
©TEREX UTILITIES. ALL RIGHTS RESERVED

CONTENTS

TECH TIP#115

TOC

4

| Lower the radial outriggers and remove guard

INTRODUCTION
STEP 1

5

| Adjust holding valve

STEP 2 - STEP 4

INTRODUCTION

This adjustment can be made for radial outriggers that drift slightly due to a latch that is out of adjustment or from thermal expansion when parked overnight in the stowed position.

STEP 1

Lower the radial outriggers and remove the guard to gain access to the holding valve (See A in the drawing below).

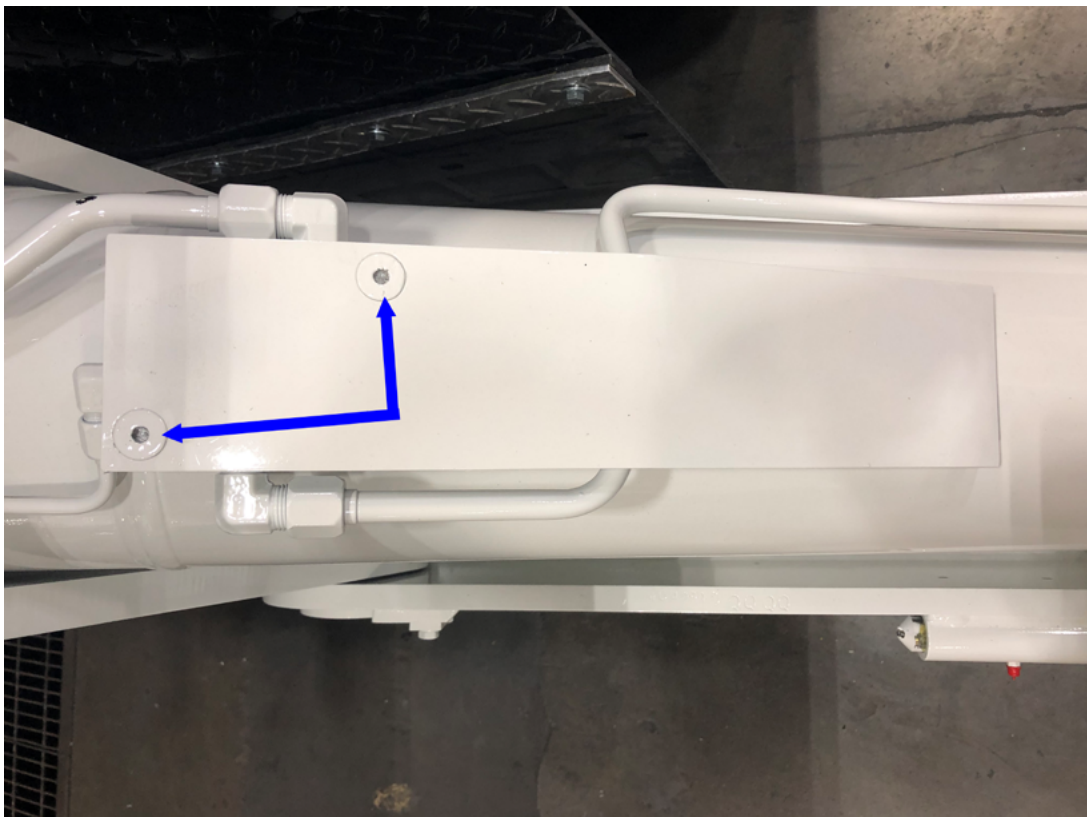
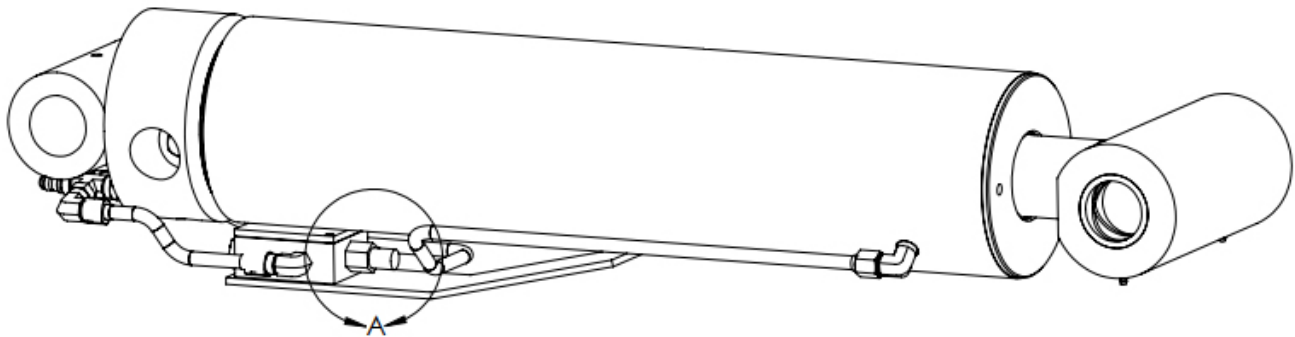

STEP 2

Remove the cap to adjust the holding valve setting.

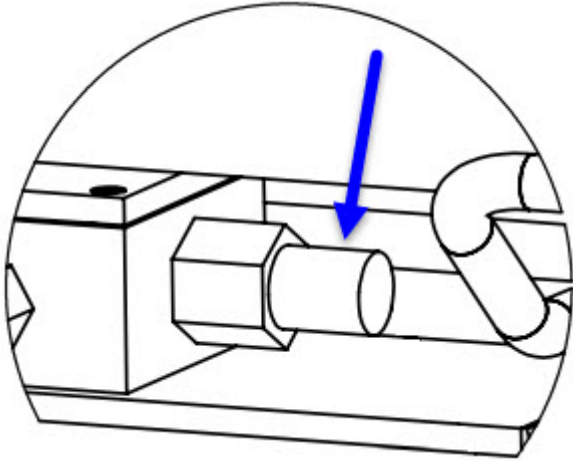

STEP 3

The holding valve is set at a 3700 psi crack pressure and is rated at 3000 psi holding pressure.

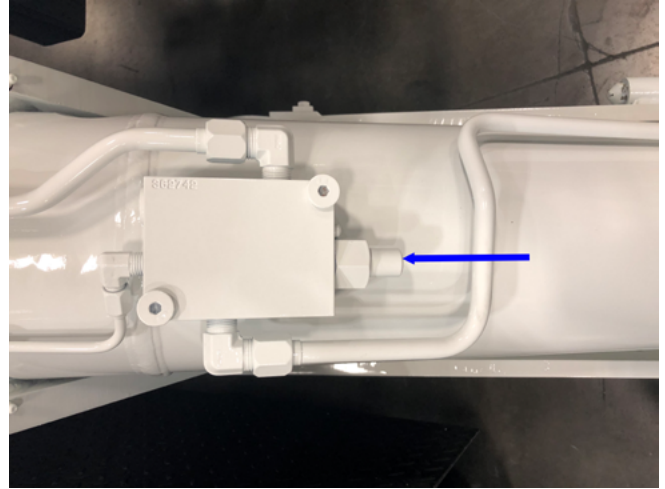

Adjust the rod side holding valve by turning it clockwise ½ of a turn.

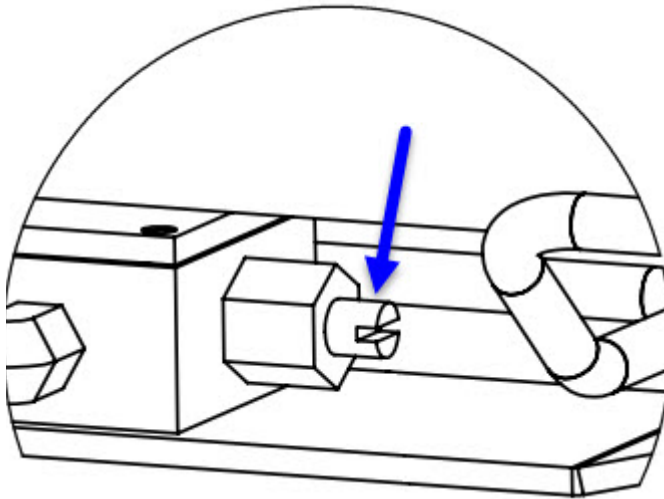

STEP 4

Mark the nut and adjustment screw with sentry seal to indicate an adjustment has been made, install the cover over the holding valve adjustment and then reinstall the cover.

Note: Excessive wear at the latch may require welding to build the area back up and allow the latch to properly secure the outrigger in the stored position.



FOR FURTHER ASSISTANCE,
CONTACT THE TEREX UTILITIES TECHNICAL SUPPORT TEAM
PHONE: **1-844-TEREX4U (1-844-837-3948)** | EMAIL: UTILITIES.SERVICE@TEREX.COM
