

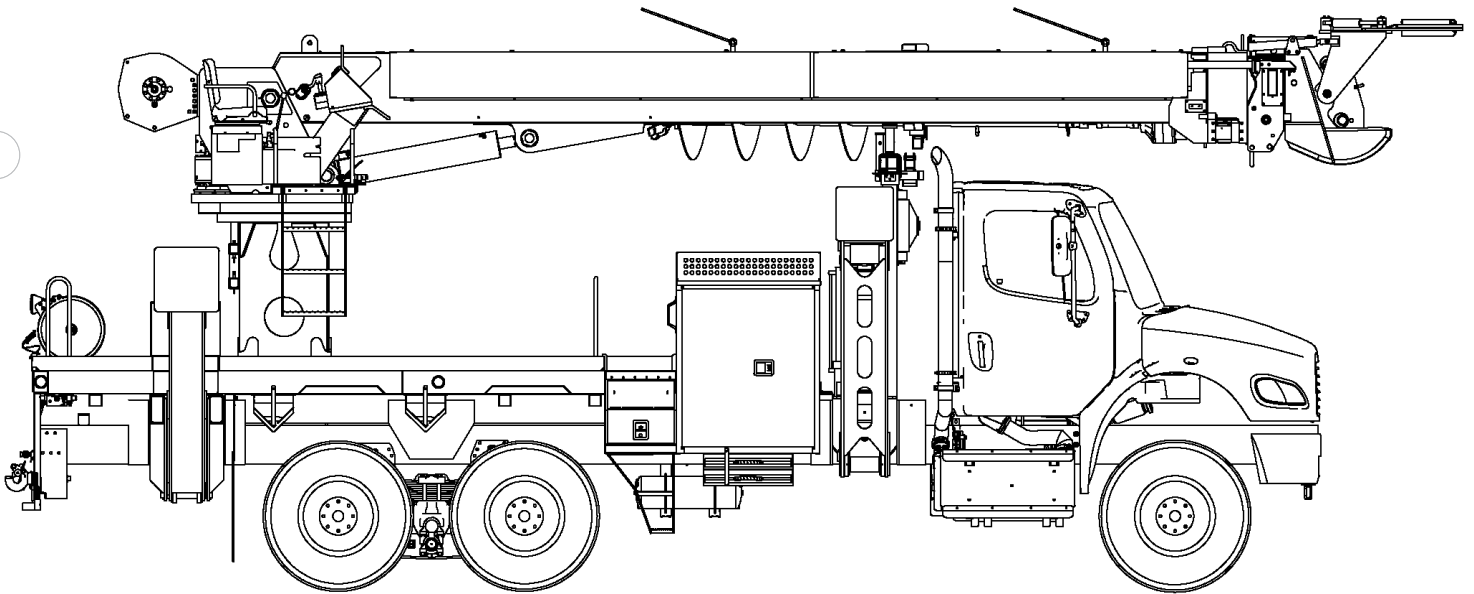

# TECH TIPS

SETTING HOP ON A GENERAL DIGGER DERRICK

NO. 135



**SERVICE CALL:**  
SETTING HOP ON A GENERAL  
DIGGER DERRICK



**MODEL(S):**  
GENERAL WITH DUAL SENSE HOP



**TOOLS NEEDED:**  
1/2", 9/16", 3/4", 1" WRENCHES  
1/4" ALLEN WRENCH  
1/4" JIC PLUG  
CALIBRATED 0-5000 PSI  
PRESSURE GAUGE

TEREX UTILITIES TECHNICAL SUPPORT TEAM

PHONE: 1-844-TEREX4U (1-844-837-3948) | EMAIL: [UTILITIES.SERVICE@TEREX.COM](mailto:UTILITIES.SERVICE@TEREX.COM)

**! WARNING**



**Injection Hazard**  
Fluid escaping under pressure can penetrate skin and result in death or serious injury.

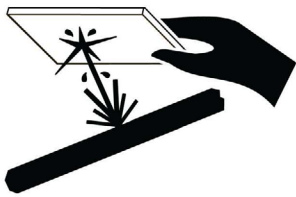

Relieve pressure before disconnecting hydraulic lines.  
Stay clear of leaks and pin holes. Use a piece of cardboard or wood to search for leaks. Do not use hand.  
Fluid injected into skin must be surgically removed within a few hours by a doctor familiar with this type of injury, or gangrene will result.



## DANGER

Failure to obey the instructions and safety rules in the appropriate Operator's Manual and Service Manual for your machine will result in death or serious injury.

Many of the hazards identified in the Operator's Manual are also safety hazards when maintenance and repair procedures are performed.

## DO NOT PERFORM MAINTENANCE UNLESS:

- ✓ You are trained and qualified to perform maintenance on this machine.
- ✓ You read, understand and obey:
  - manufacturer's instructions and safety rules
  - employer's safety rules and worksite regulations
  - applicable governmental regulations
- ✓ You have the appropriate tools, lifting equipment and a suitable workshop.

The information contained in this Tech Tip is a supplement to the Service Manual. Consult the appropriate Service Manual of your machine for safety rules and hazards.



TECH TIP 135 | RELEASED 12.22.2023 | VERSION 1.0  
©TEREX UTILITIES. ALL RIGHTS RESERVED

# CONTENTS

## TECH TIP #135

### TOC

4

| *Introduction*

**STEP 1 - STEP 2**

6

| *Position boom*

**STEP 4 - STEP 7**

7

| *Test HOP*

| *Adjust sensing valve*

**STEP 8 - STEP 11**



Repair procedures shall be completed by a person trained and qualified on the repair of this machine



Immediately tag and remove from service a damaged or malfunctioning machine



Read this procedure completely and adhere to the instructions. Attempting shortcuts may produce hazardous conditions

## STEP 1

Review the following tech-tips before proceeding:

**Tech Tip #02** - Adjusting System Relief Pressure

**Tech Tip #10** - Setting Boom HOP (Hydraulic Overload Protection)

**Tech Tip #38** - Adjustable Hydraulic Valves

---

## STEP 2

The General Digger Derrick, if equipped with a Dual Pressure Valve to Increase Digging, will have two different pressures for boom up. This will require two different pressure settings for the HOP system. Units with this option will have a switch at the junction of the boom and turret, shown in pictures below.

This switch closes at zero degrees boom angle, relative to the turret base plate. This then closes the solenoid valve located downstream in the boom up pressure relief line, preventing it from limiting boom up pressure to 2500psi while the boom is below zero degrees.

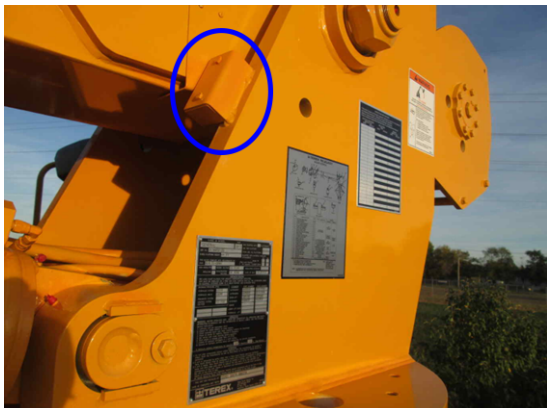

## STEP 2 (Continued)

Verify the boom angle switch activates the solenoid at 0 degrees and lower before proceeding.

## STEP 3

The unit will have two sensing valves installed, usually located on the side of the turret.

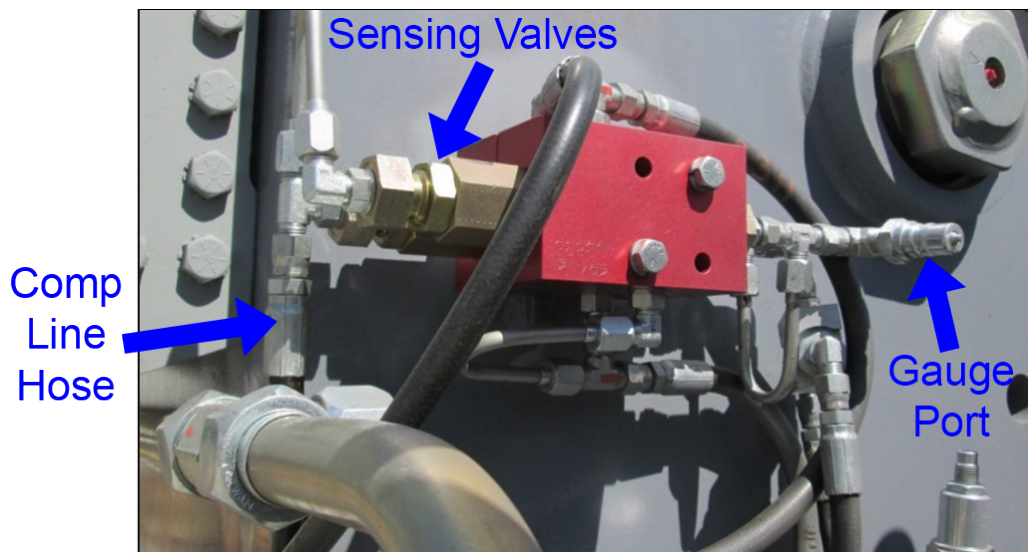
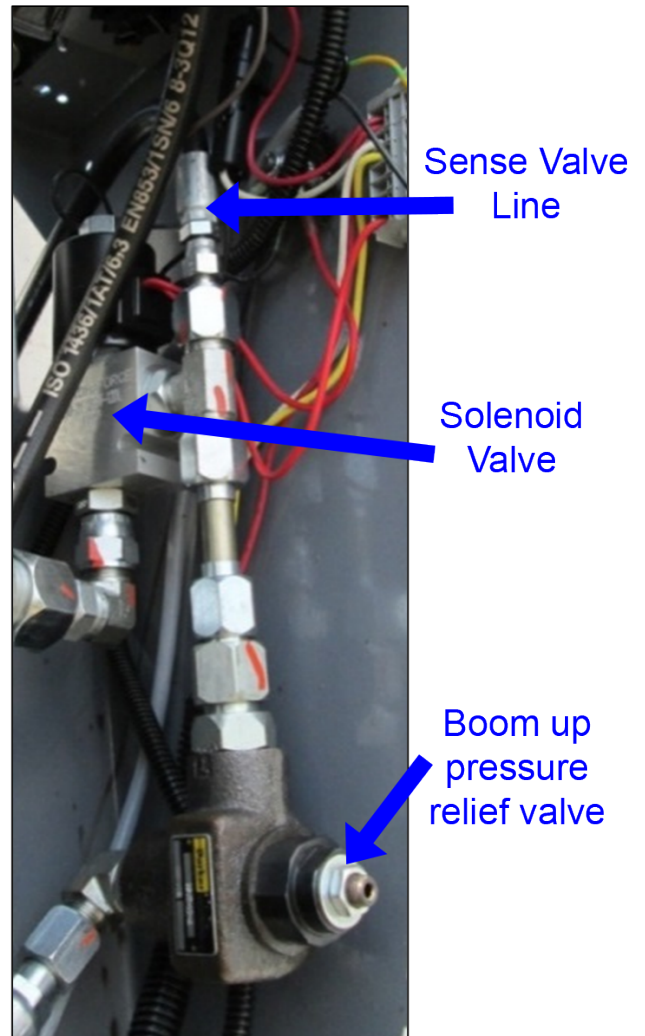



## STEP 4

Prepare the unit for testing by placing the boom in the rest and installing a pressure gauge at the gauge port. Remove and plug the “Comp” hose, leaving the fitting at the sense valves open.

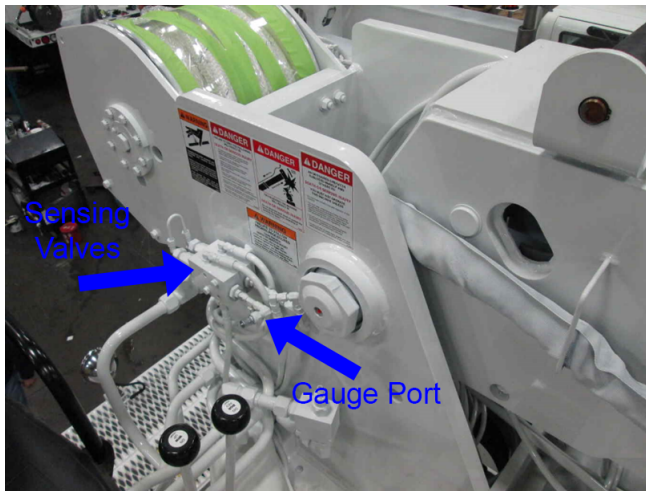

## STEP 5

Raise the boom all the way up, do not run out of cylinder stroke at full speed. Activate (tape, tie wrap, bungee cord) and keep activated the zero degree boom angle switch. With the control handle in the up position and the engine throttle at the maximum setting, read the pressure gauge. Boom up pressure with the switch activated is system pressure and should be set at 3000 psi, adjust if necessary.



**CW to increase, CCW to decrease**

## STEP 6

Boom down approximately 10 degrees, release the activation method used in Step 5. Raise the boom all the way up, do not run out of cylinder stroke at full speed. With the control handle in the up position and the engine throttle at the maximum setting, read the pressure gauge. Boom up pressure should be 2500 psi adjust as necessary at the relief valve shown in the picture in step 2.

## STEP 7

Lower the boom and return the boom angle switch to normal operation. Position the boom for HOP testing with the second section extended at a 45 degree angle as shown in **Tech Tip #10**.

**Figure 7**



Escaping fluid under pressure can penetrate skin causing serious injury.

Relieve pressure before disconnecting hydraulic lines. Keep away from leaks and pin holes. Use a piece of cardboard or paper to search for leaks. **DO NOT** use your hand.



## STEP 8

Connect the load line up to a load that is at least 1.5 times the load chart value in the boom configuration used while setting the pressure. HOP settings are most accurate if the load cannot move when setting the pressure.

The HOP system should trip between 2700 and 2750 psi. If it doesn't trip in this range, adjust the sensing valve that has its T port plumbed in with the boom up pressure relief valve. It may also be identified by the adjuster not screwed in as far as the other sensing valve.

**FIGURE 7**



## STEP 9

Activate and keep activated the boom angle switch, then repeat Step 8. The HOP system should trip at 3200 psi. Adjust the other sensing valve as needed.

## STEP 10

Mark a straight line across the two fittings with paint or with a permanent marker. See **Figure 1** for an example of this marking.

## STEP 11

If you have any questions about this procedure or values for the unit, please contact Terex Utilities Technical Support at: (844) 837-3948, or [utilities.service@terex.com](mailto:utilities.service@terex.com).



Ensure all decals are in place when operating equipment.





FOR FURTHER ASSISTANCE,

CONTACT THE TEREX UTILITIES TECHNICAL SUPPORT TEAM

PHONE: [1-844-TEREX4U \(1-844-837-3948\)](tel:1-844-TEREX4U) | EMAIL: [UTILITIES.SERVICE@TEREX.COM](mailto:UTILITIES.SERVICE@TEREX.COM)

---