

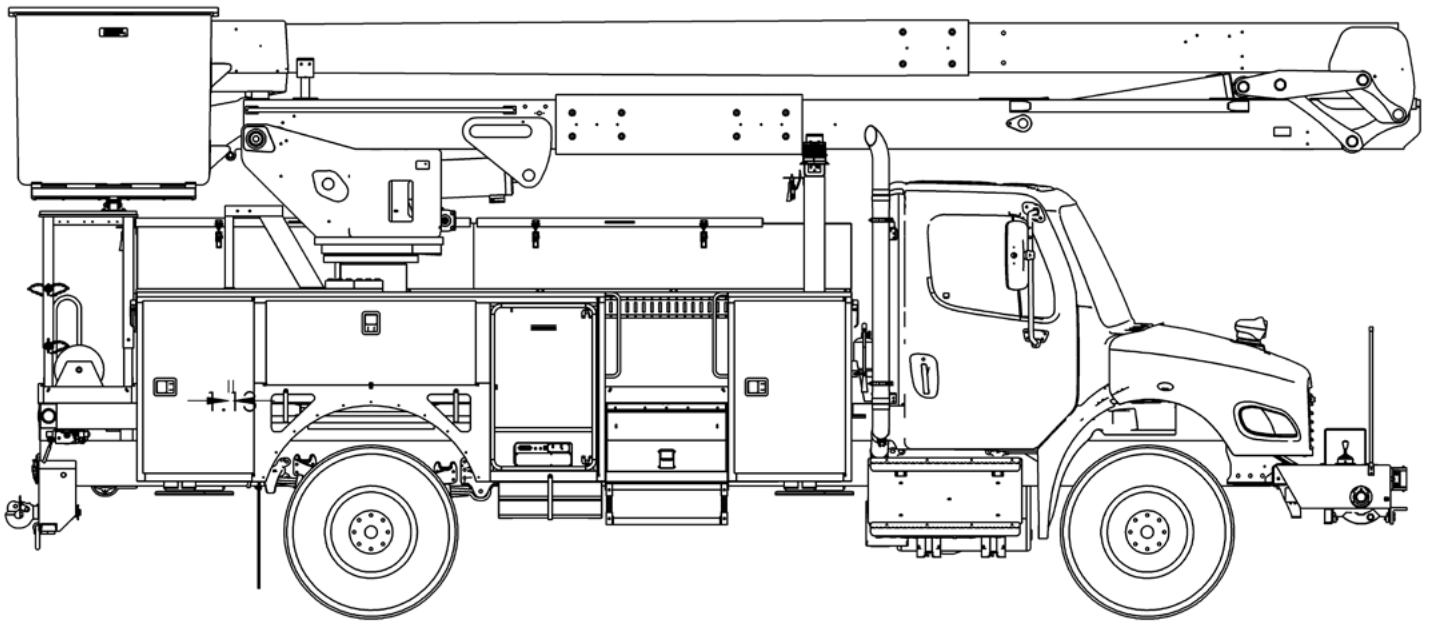

TECH TIPS

SETTING STOP VALVES FOR NON-OVERCENTER RM AND RMX UNITS

NO. 17



SERVICE CALL:
SETTING STOP VALVES FOR NON-OVERCENTER RM AND RMX UNITS



MODEL(S):
RM AND RMX



TOOLS NEEDED:
1/2" WRENCH
1/2" SOCKET
2 LB RUBBER HAMMER
ANGLE INDICATOR
SCREW DRIVER SET

TEREX UTILITIES TECHNICAL SUPPORT TEAM

PHONE: 1-844-TEREX4U (1-844-837-3948) | EMAIL: UTILITIES.SERVICE@TEREX.COM

! WARNING



Injection Hazard
Fluid escaping under pressure can penetrate skin and result in death or serious injury.



Relieve pressure before disconnecting hydraulic lines.
Stay clear of leaks and pin holes. Use a piece of cardboard or wood to search for leaks. Do not use hand.
Fluid injected into skin must be surgically removed within a few hours by a doctor familiar with this type of injury, or gangrene will result.



DANGER

Failure to obey the instructions and safety rules in the appropriate Operator's Manual and Service Manual for your machine will result in death or serious injury.

Many of the hazards identified in the Operator's Manual are also safety hazards when maintenance and repair procedures are performed.

DO NOT PERFORM MAINTENANCE UNLESS:

- ✓ You are trained and qualified to perform maintenance on this machine.
- ✓ You read, understand and obey:
 - manufacturer's instructions and safety rules
 - employer's safety rules and worksite regulations
 - applicable governmental regulations
- ✓ You have the appropriate tools, lifting equipment and a suitable workshop.

The information contained in this Tech Tip is a supplement to the Service Manual. Consult the appropriate Service Manual of your machine for safety rules and hazards.



TECH TIP 17 | RELEASED 03.03.2022 | VERSION 1.0
©TEREX UTILITIES. ALL RIGHTS RESERVED

CONTENTS

TECH TIP#17

TOC

4 INTRODUCTION

5 STOP VALVE LOCATIONS

6 | *Locate and level the unit*
STEP 1 - STEP 3

7 | *Adjust the stop valve*
| *Boom angles*
STEP 4 - STEP 5

INTRODUCTION

The purpose of the stop valves is to limit the upper boom from going over-center when operating the upper boom up and the lower boom down on RM or RMX models. The purpose of the slow valve is to slow down the upper boom up function to alert the operator before the upper boom gets to the stop valve.

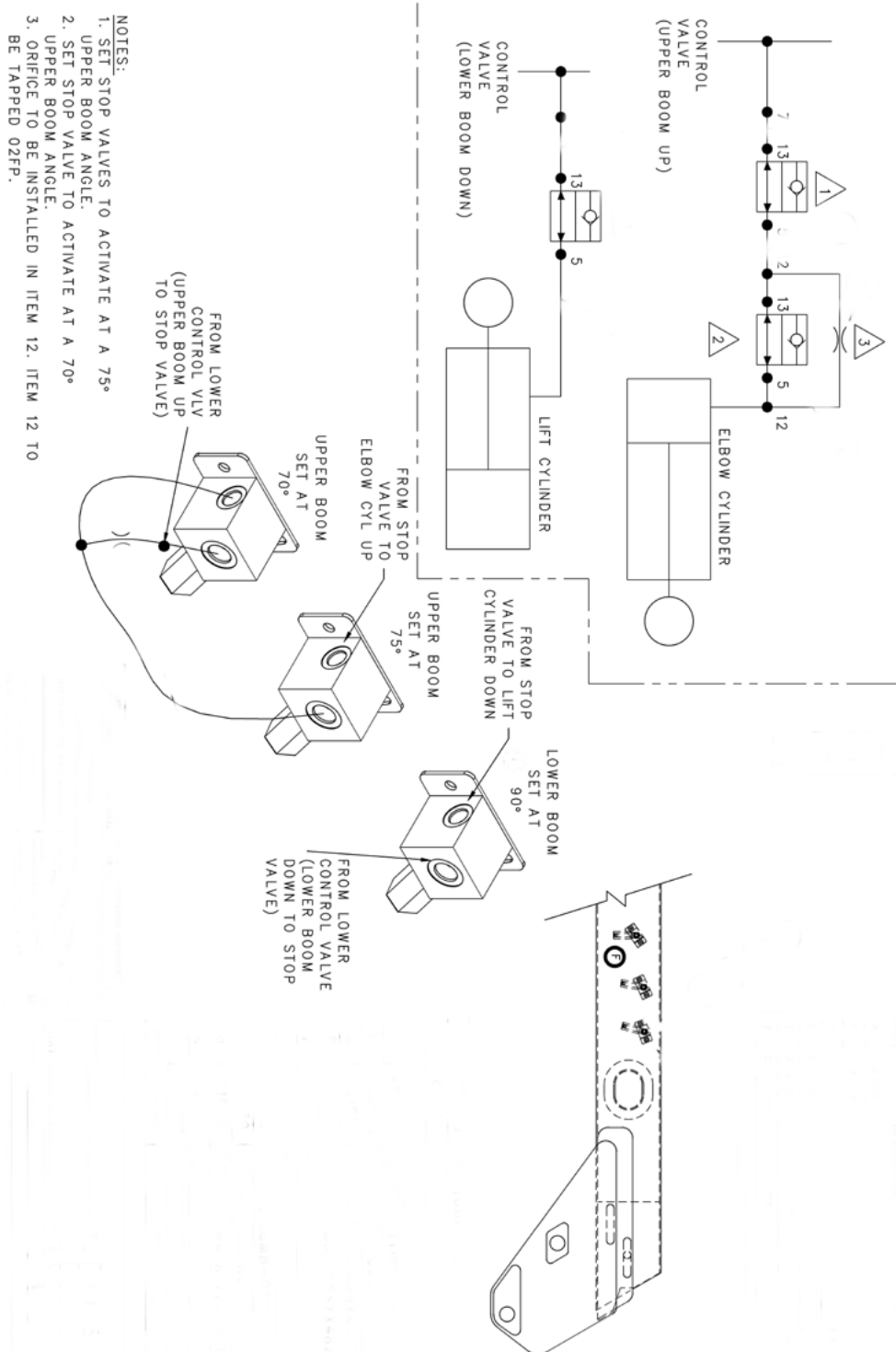

STOP VALVE LOCATIONS

- Upper Boom Slow - 70 Degrees
- Upper Boom Stop - 75 Degrees
- Lower Boom Stop - 90 Degrees

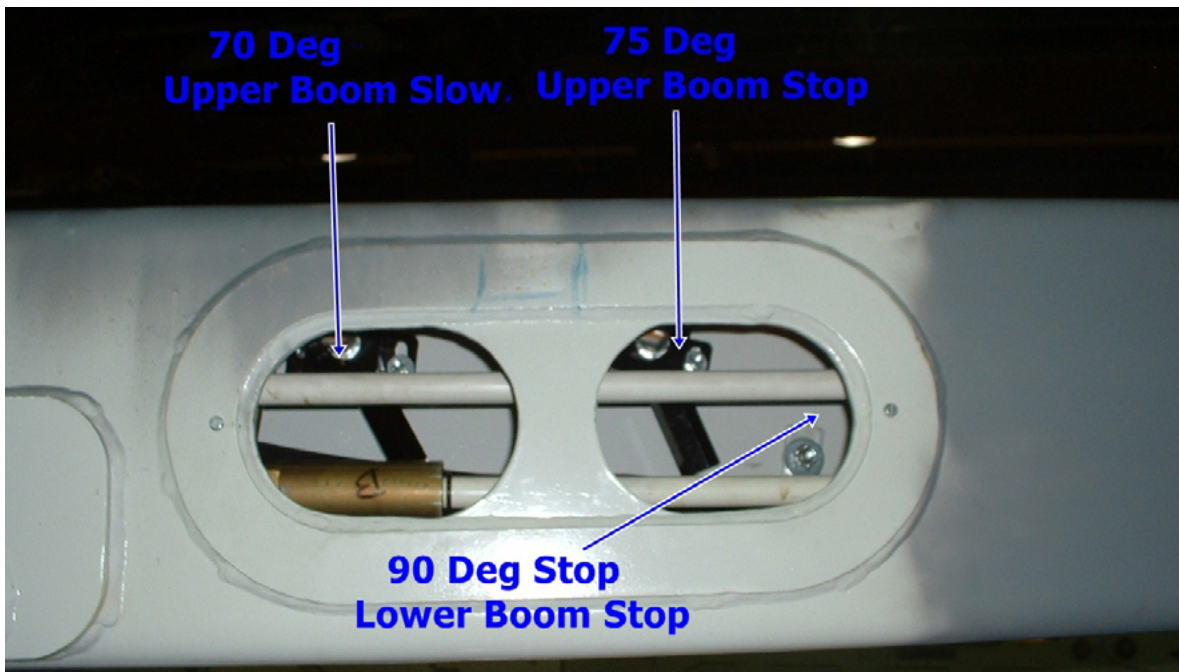
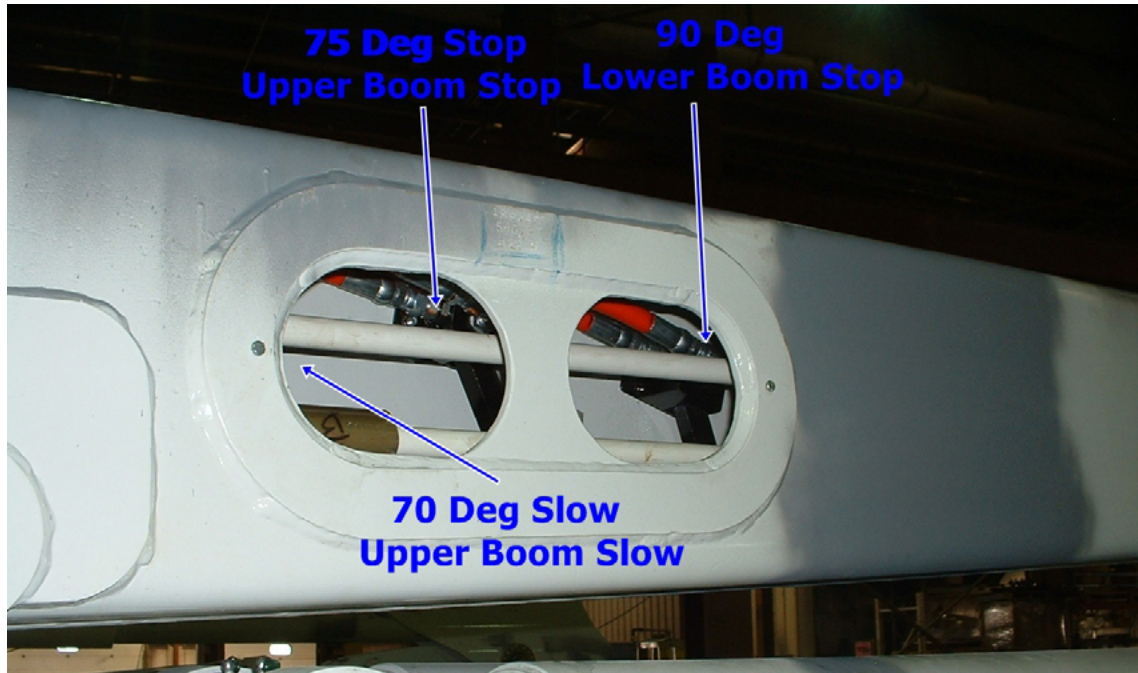

STEP 1

Locate the machine in an area that will allow you to run the upper boom up without any overhead restrictions.

STEP 2

Level the machine, making sure that the pedestal is also level.



STEP 3

Raise the Upper Boom and check the angle. Lower the Upper Boom Down and verify the angle again.



STEP 4

Adjust the stop valve to the proper angle using the information supplied below for models RM and RMX.

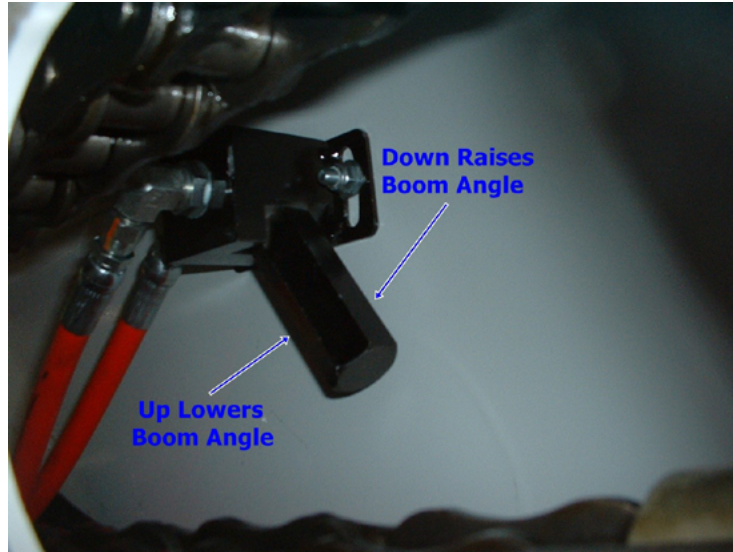

BOOM ANGLES

- Upper Boom Slow set at 70 Deg
- Upper Boom Stop set at 75 Deg

The Lower Boom Stop is set when the Upper Boom is at 90 Degrees when lowering the Lower Boom down.

Set by running the lower boom up to 45 degrees, then running the upper boom up to the 75 degree stop, then running the lower boom down until it stops.

STEP 5

Repeat steps until properly adjusted.





FOR FURTHER ASSISTANCE,
CONTACT THE TEREX UTILITIES TECHNICAL SUPPORT TEAM
PHONE: **1-844-TEREX4U (1-844-837-3948)** | EMAIL: **UTILITIES.SERVICE@TEREX.COM**
