

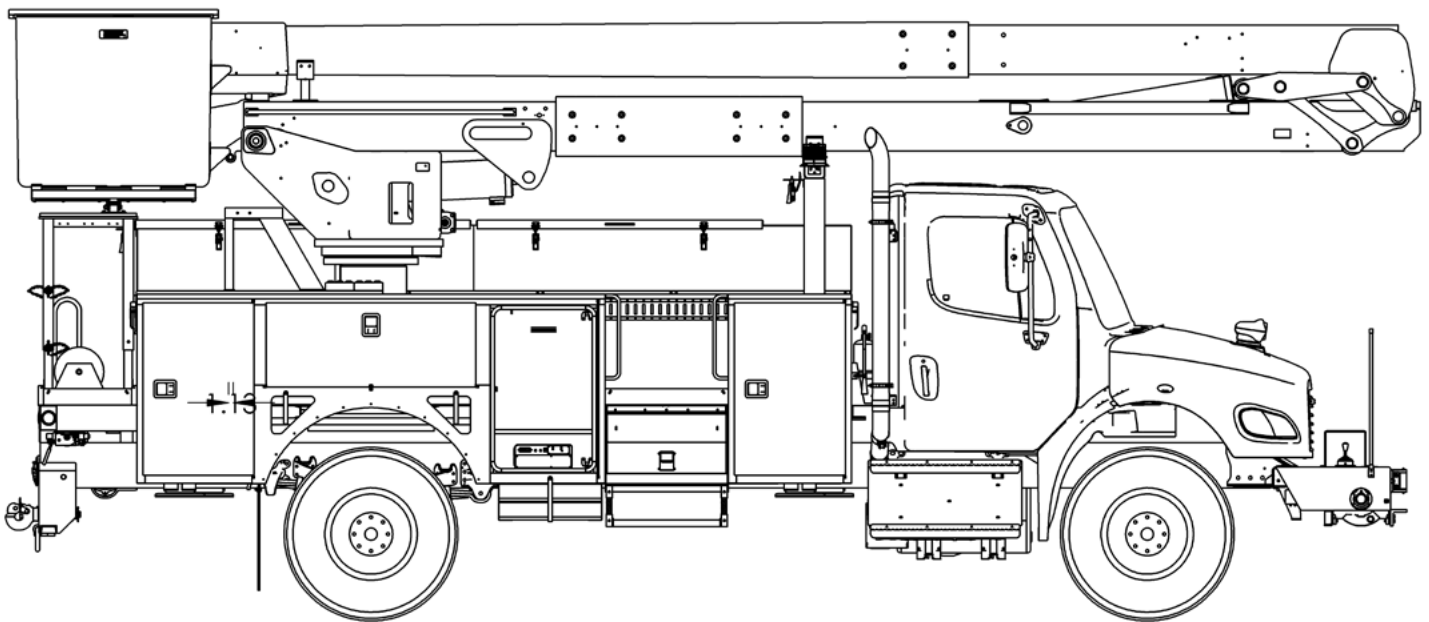

TECH TIPS

TROUBLESHOOTING THE TEREX LIGHT DUTY CHASSIS CONTROLLER

NO. 40



SERVICE CALL:
TROUBLESHOOTING THE
TEREX LIGHT DUTY CHASSIS
CONTROLLER



MODEL(S):
ALL TEREX UTILITIES UNITS
EQUIPPED WITH THE LIGHT DUTY
TEREX CHASSIS CONTROLLER



TOOLS NEEDED:
BASIC HAND TOOLS
INCANDESCENT TEST LIGHT
DIGITAL MULTIMETER
CHASSIS CONTROLLER MANUAL
ELECTRICAL SCHEMATIC

TEREX UTILITIES TECHNICAL SUPPORT TEAM

PHONE: 1-844-TEREX4U (1-844-837-3948) | EMAIL: UTILITIES.SERVICE@TEREX.COM



DANGER

Failure to obey the instructions and safety rules in the appropriate Operator's Manual and Service Manual for your machine will result in death or serious injury.

Many of the hazards identified in the Operator's Manual are also safety hazards when maintenance and repair procedures are performed.

DO NOT PERFORM MAINTENANCE UNLESS:

- ✓ You are trained and qualified to perform maintenance on this machine.
- ✓ You read, understand and obey:
 - manufacturer's instructions and safety rules
 - employer's safety rules and worksite regulations
 - applicable governmental regulations
- ✓ You have the appropriate tools, lifting equipment and a suitable workshop.

The information contained in this Tech Tip is a supplement to the Service Manual. Consult the appropriate Service Manual of your machine for safety rules and hazards.



TECH TIP 40 | RELEASED 03.24.2022 | VERSION 1.0
©TEREX UTILITIES. ALL RIGHTS RESERVED

CONTENTS

TECH TIP#40

TOC

4

| Verify 12V power and ground

INTRODUCTION
STEP 1 - STEP 4

9

| Continue troubleshooting with the manual

STEP 12

5

| Engage parking brake

| Verify LED lights

STEP 5

6

| Check Master Power, PTO Power, and Pressure LED

STEP 7 - STEP 7

7

| Check K2 and K3 LED lights

STEP 8 - STEP 9

8

| Check Aux Power, Start/Stop, and K1

STEP 10 - STEP 11

INTRODUCTION

Chassis Controller Manual (P/N 607223): can be found with Unit Maintenance Manual or in the kitsheet portion of the CD supplied with unit.

Unit Specific Electrical Schematic

- A copy of the unit specific Electrical Schematic is provided with the final paperwork when the unit is shipped
- Contact your authorized Terex Utilities Branch or Dealer for replacement schematics

Reference Tech-tip #39 to determine which chassis controller is installed on your unit.

STEP 1

Locate the Terex Chassis Controller manual for your unit. This is an appendix to the unit Maintenance Manual.

STEP 2

Refer to the electrical schematic specific to your unit.

STEP 3

Turn the ignition key to the ON position (Do not start the chassis engine), set the Park Brake, and ensure transmission is in Park.

STEP 4

Check for the following:

- Verify 12V power at the Power connection on the lower left side of controller. PWR LED light should be on solid (not flashing) at right side of the controller. This should be lit with the same intensity as hooking test light to the chassis battery. Controller will not work correctly without a good power source and correct input voltage. **FIGURE 1**
- Verify the ground is good at the Ground connection at the lower left side of controller. Controller will not work correctly without good ground direct to the battery.
- COM light should also be on and not flashing.

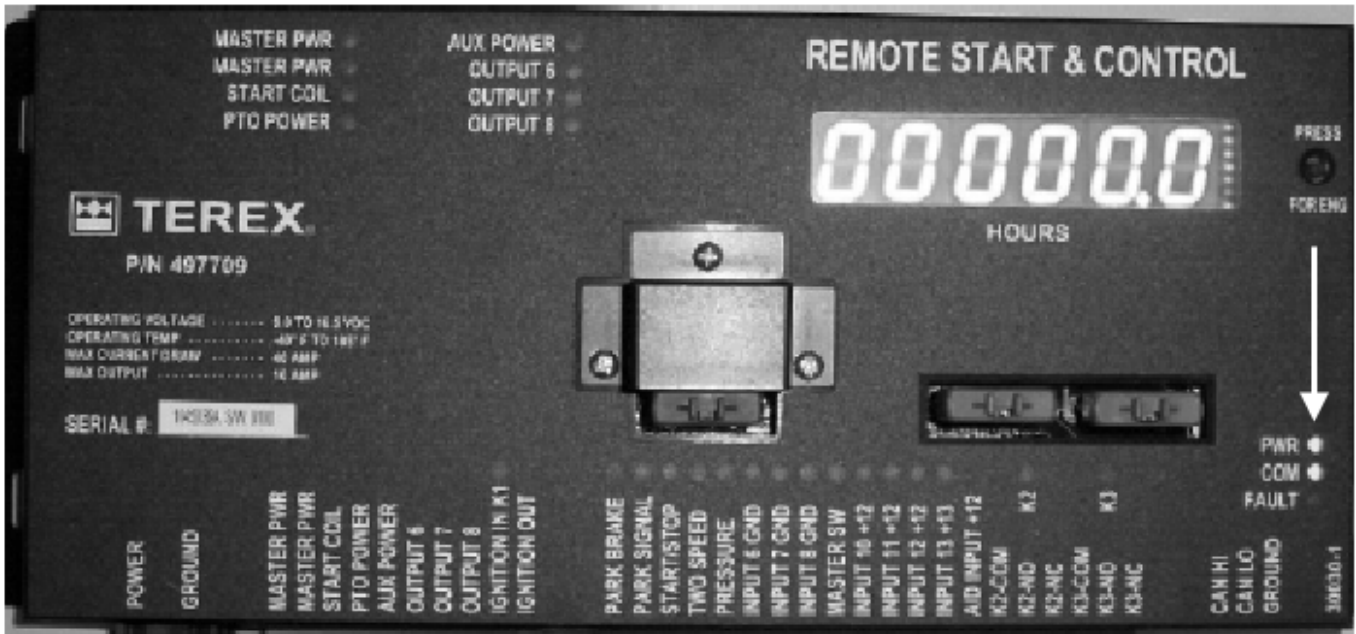
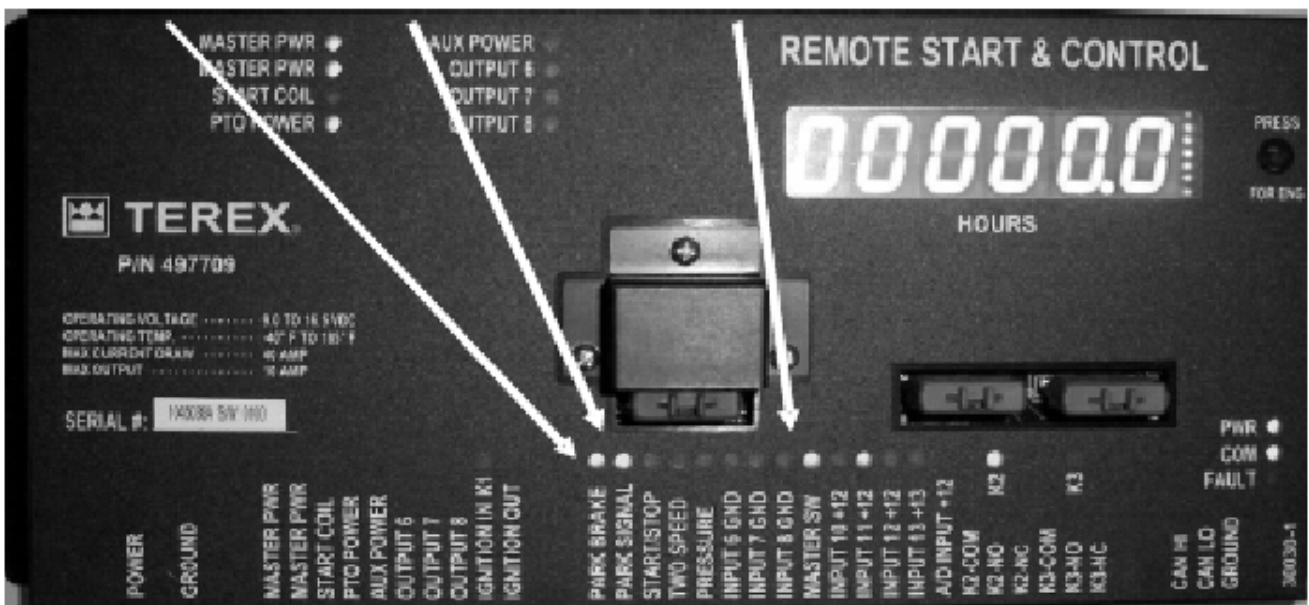

FIGURE 1

STEP 5

With Park Brake set, Transmission in Park, and Master switch ON, the LED next to each of these inputs should light up. This is along the lower part of panel. If not, trace input and correct fault as needed.



STEP 6

When the LED's in step 5 are lit, the LED by Master PWR and PTO Power should also be on.

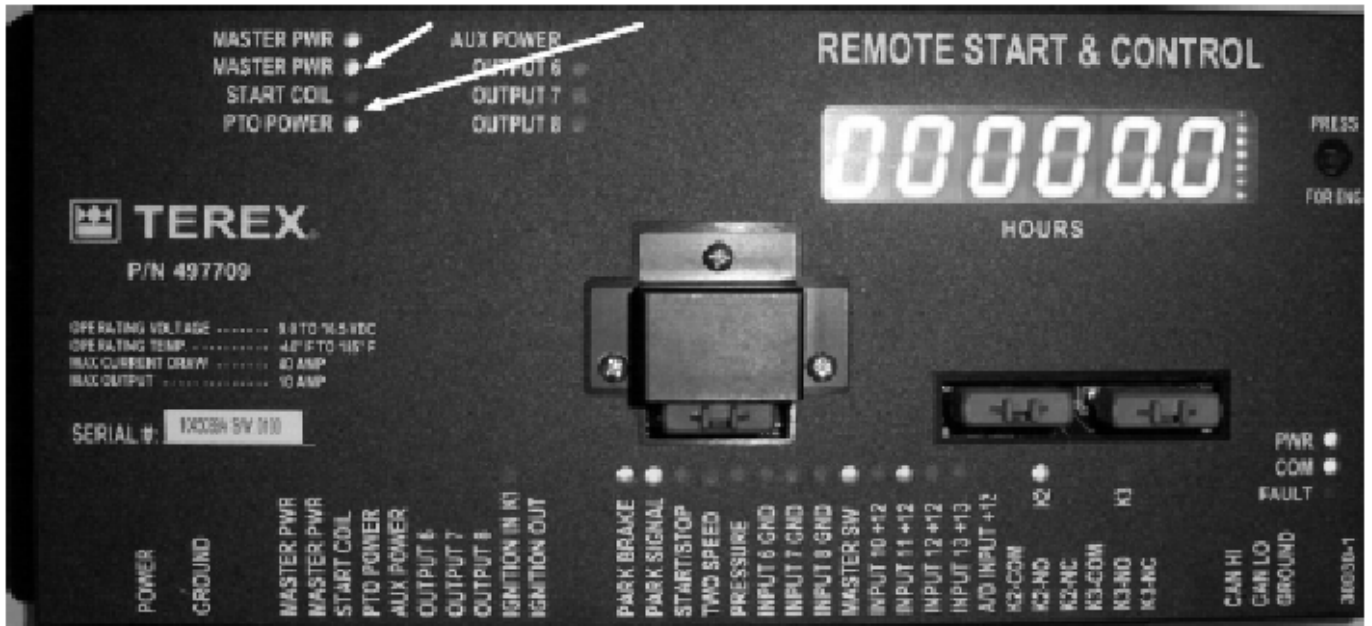

STEP 7

If the PTO is engaged and the pressure switch that senses this is closed, the LED next to Pressure will be on. If not, trace down fault in pressure switch or wiring to switch..

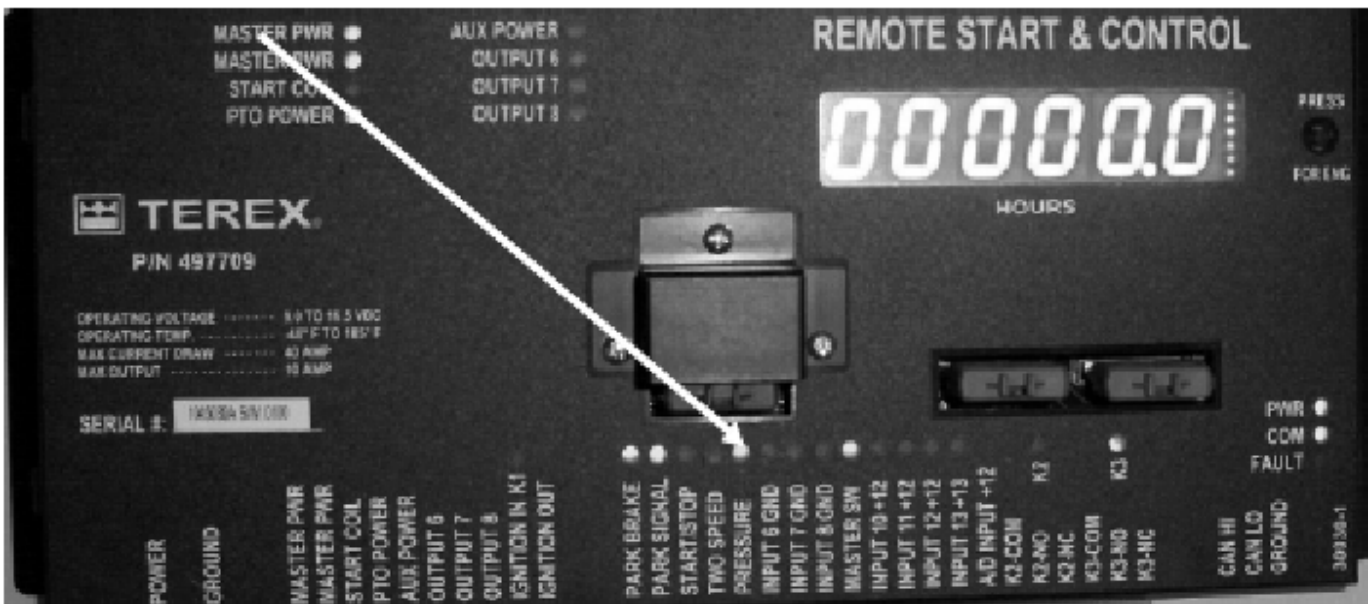

STEP 8

With engine running and PTO engaged, LED next to K2 should be on. Engine throttle should be at the pre-set RPM at this time.

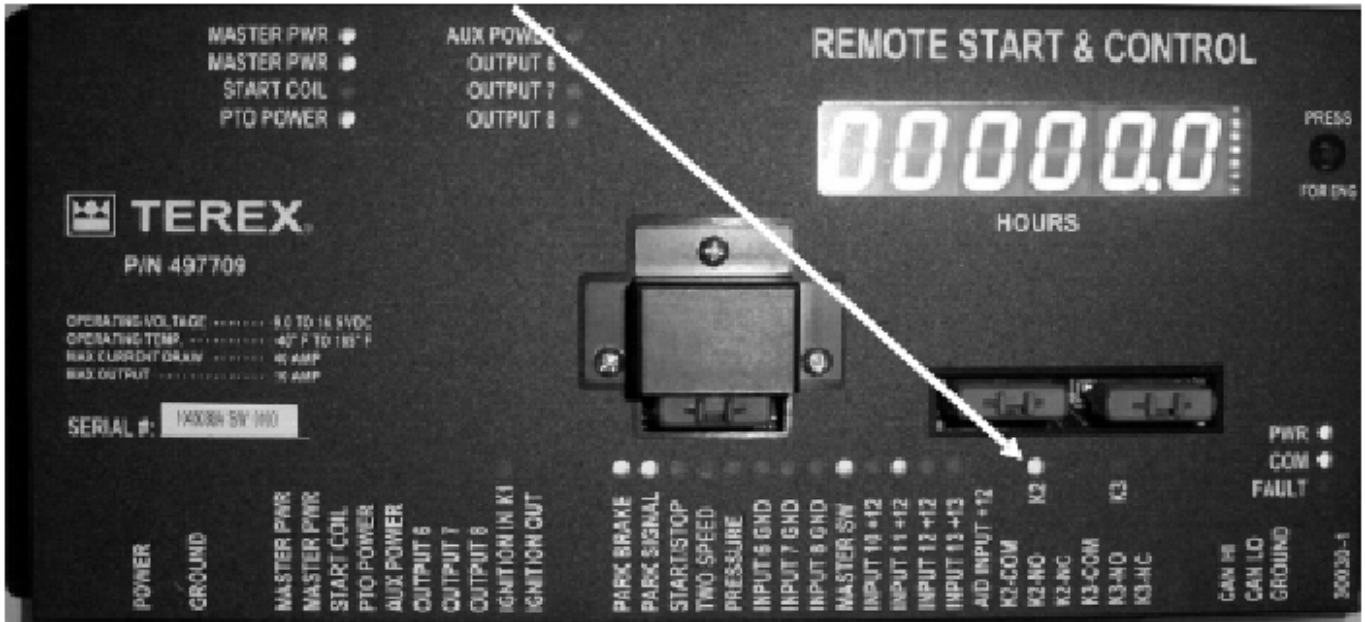

STEP 9

If unit has two speed switch or demand throttle, LED at K3 will be on when throttle is commanded up.

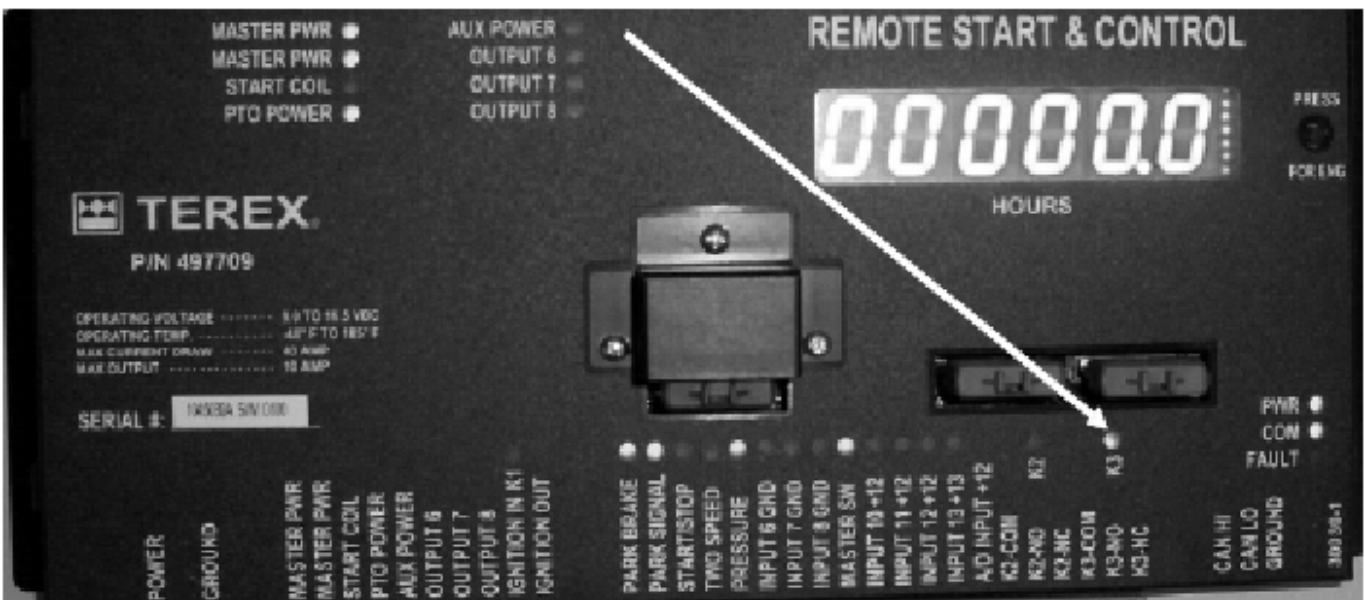

STEP 10

If unit is equipped with auxiliary power and the engine is not running (Pressure LED off), activation of the two speed switch will signal the auxiliary power to come on. This will be indicated by Aux Power LED at top of panel.

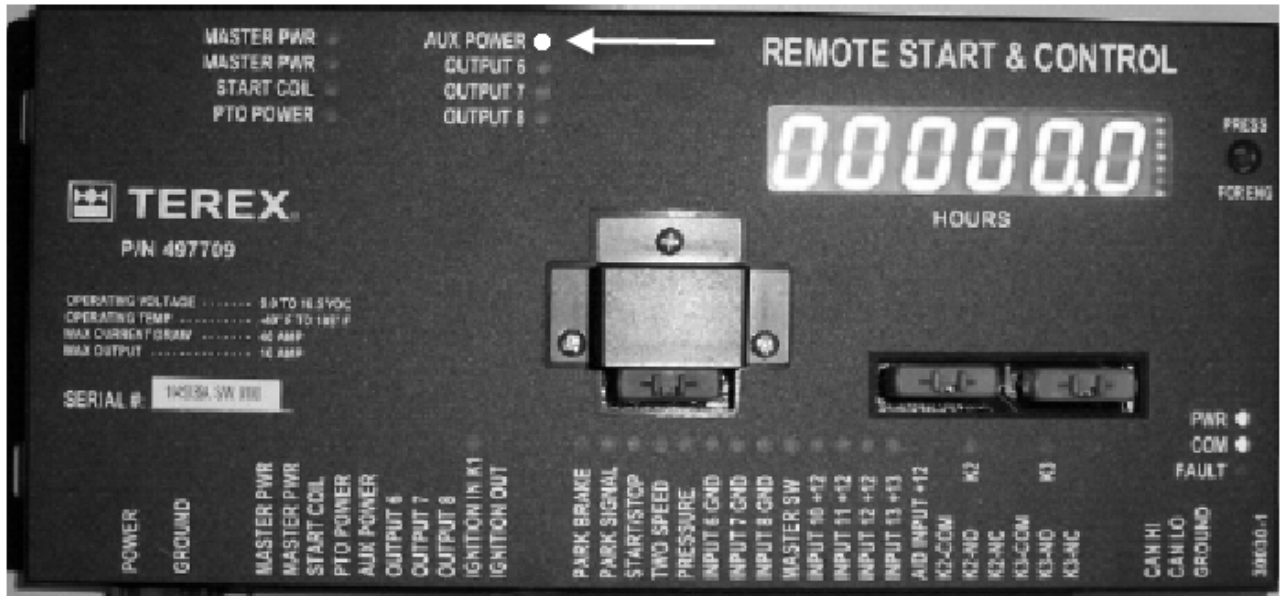

STEP 11

The Start/Stop LED will come on when this function is activated. When Start signal is given, LED at Start Coil should come on; indicating signal is being sent to chassis starter. The K1 LED will be ON when in Stop Mode.

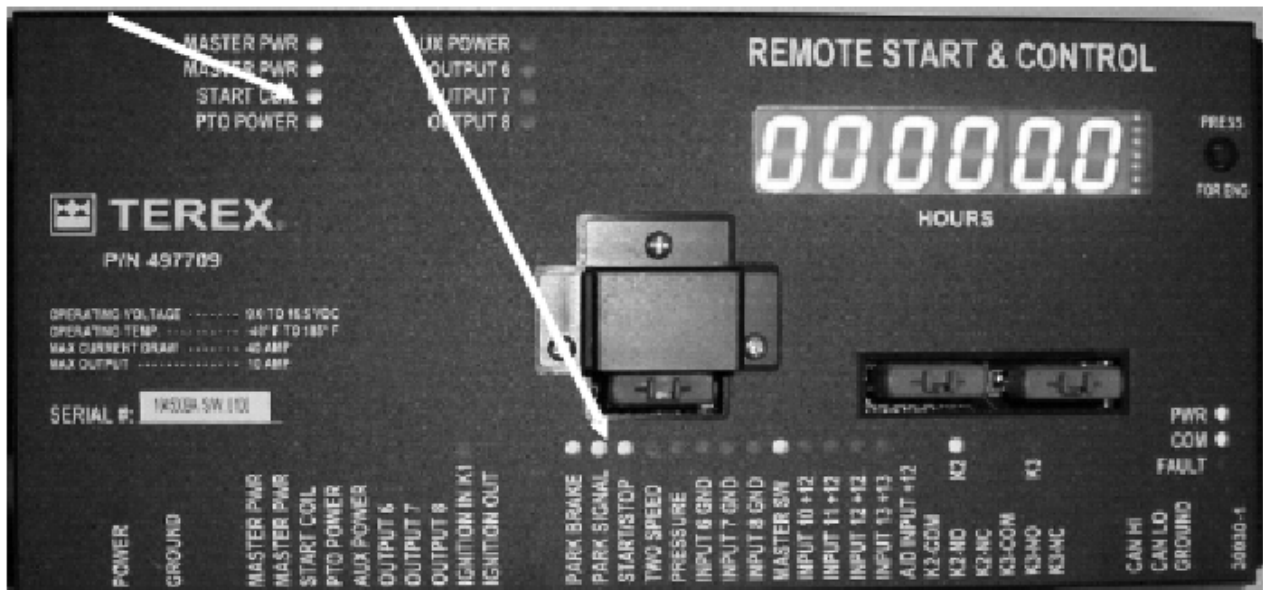

The K1 LED will be ON when in Stop Mode.

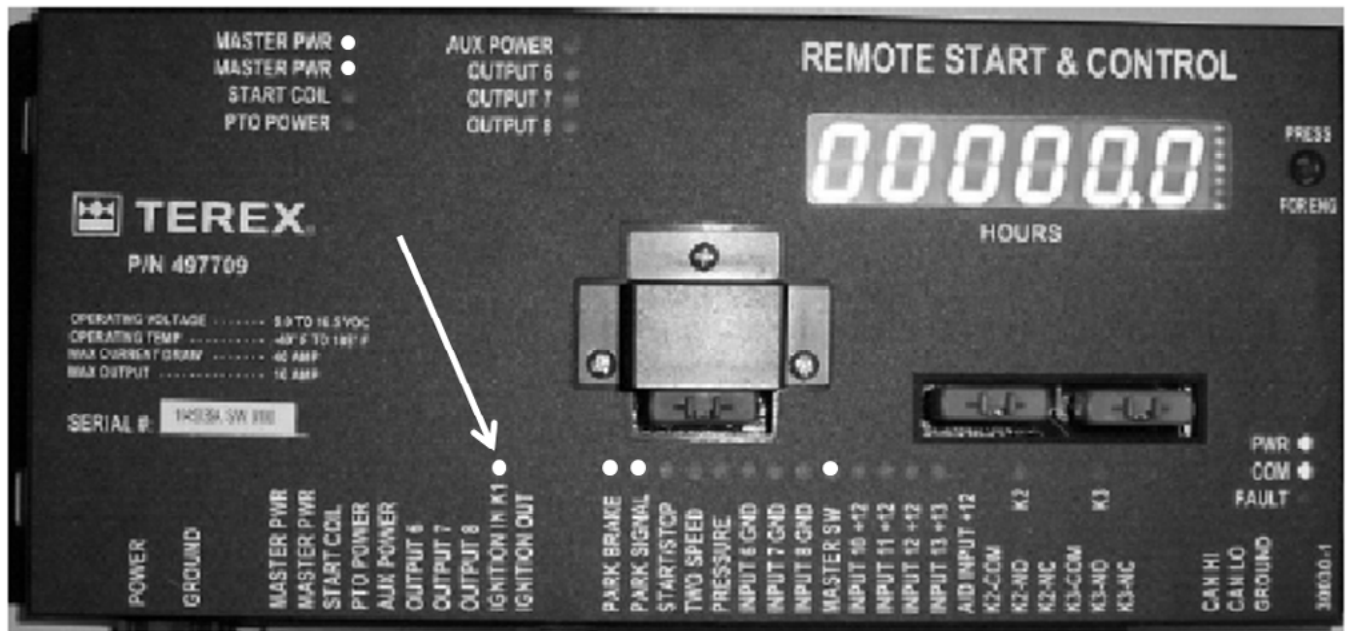

STEP 12

Continue the troubleshooting process using this Tech Tip and the Terex Chassis Control Manual troubleshooting guide.



FOR FURTHER ASSISTANCE,
CONTACT THE TEREX UTILITIES TECHNICAL SUPPORT TEAM
PHONE: **1-844-TEREX4U (1-844-837-3948)** | EMAIL: **UTILITIES.SERVICE@TEREX.COM**
