

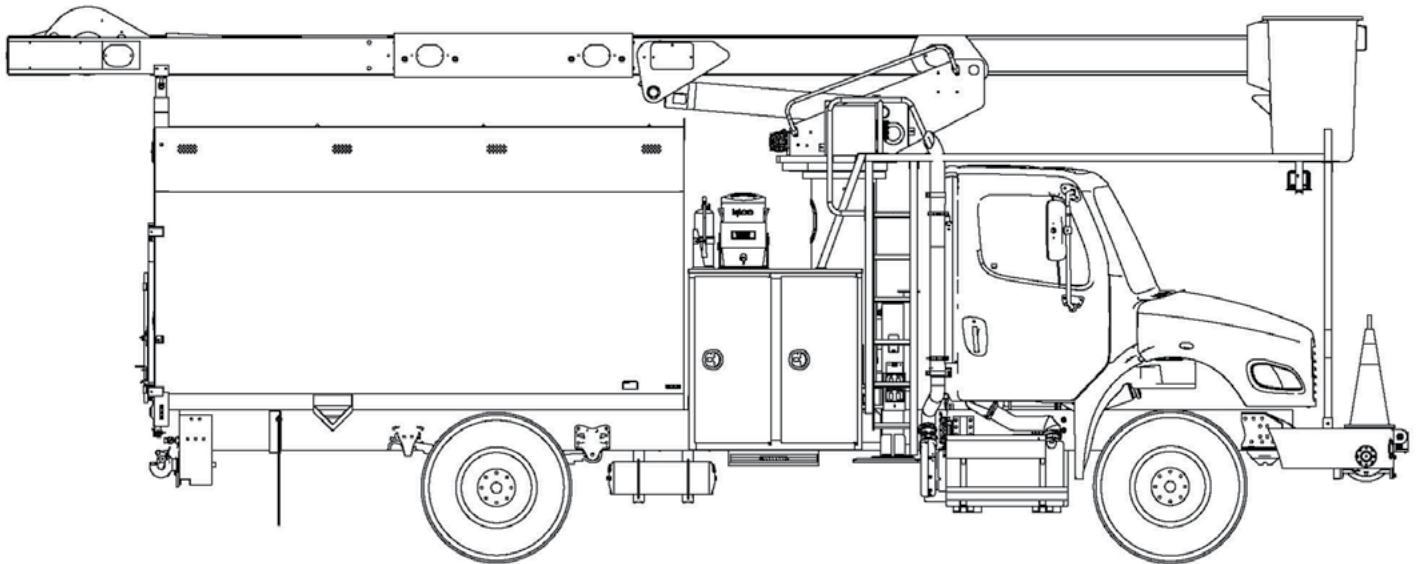

TECH TIPS

INSULATED BOOM FAILS TO PASS A DIELECTRIC TEST

NO. 51



SERVICE CALL:
INSULATED BOOM FAILS TO PASS
A DIELECTRIC TEST



MODEL(S):
ALL INSULATED AERIAL DEVICES
AND DIGGER DERRICKS



TOOLS NEEDED:
SCOTCH BRITE PADS (FINE
ABRASIVE)
100 GRIT SANDPAPER

TEREX UTILITIES TECHNICAL SUPPORT TEAM

PHONE: 1-844-TEREX4U (1-844-837-3948) | EMAIL: UTILITIES.SERVICE@TEREX.COM



DANGER

Failure to obey the instructions and safety rules in the appropriate Operator's Manual and Service Manual for your machine will result in death or serious injury.

Many of the hazards identified in the Operator's Manual are also safety hazards when maintenance and repair procedures are performed.

DO NOT PERFORM MAINTENANCE UNLESS:

- ✓ You are trained and qualified to perform maintenance on this machine.
- ✓ You read, understand and obey:
 - manufacturer's instructions and safety rules
 - employer's safety rules and worksite regulations
 - applicable governmental regulations
- ✓ You have the appropriate tools, lifting equipment and a suitable workshop.

The information contained in this Tech Tip is a supplement to the Service Manual. Consult the appropriate Service Manual of your machine for safety rules and hazards.



TECH TIP 51 | RELEASED 07.26.2022 | VERSION 1.0
©TEREX UTILITIES. ALL RIGHTS RESERVED

CONTENTS

TECH TIP#51

TOC

4 INTRODUCTION

5 | *Clean the boom*
INTRODUCTION
STEP 1

6 | *Dry the boom*
| *Perform dielectric test*
| *Remove components*
STEP 2 - STEP 6

7 STEP 7 - STEP 8

INTRODUCTION

Dielectric tests are performed to verify the insulated portion of the machine provides the insulation expected. The ambient conditions and cleanliness and condition of the insulating parts will vary the test results. The dielectric test consists of applying a voltage to metal components at one end of an insulating section and measuring the leakage current that will go through the insulating part to metal at the other end as the current travels to ground. There are two different types of dielectric tests. The Qualification test performed at the factory qualifies a machine for the specific insulating rating. The Maintenance test will determine if the boom continues to provide the expected insulation. The test procedures are established by ANSI A92.2 and A10.31 to provide consistent methods to measure the leakage current at specific voltages determined by the voltage rating of the unit. The upper boom insulation determines what the voltage rating of the machine will be.

The platform liner and the lower boom insert will be tested only; they do not have an insulating rating. The high resistance single stick controls are tested only and do not have an insulating rating and are not considered part of the insulating system. Be aware that units built before 2010 with plastic handles have a different test voltage when installed on the unit.

Dielectric tests are performed for a number of reasons such as: on a new machine before delivery, periodically per ANSI standards, whenever repairs are made to components in the insulated section or whenever a problem is suspected.

If the unit has not had a dielectric test performed within the last year, as required by ANSI and OSHA, it cannot be considered insulated.

Failure to pass the dielectric test is not covered by structural warranty. Use, exposure to sunlight, condition, damage, and cleanliness of the boom and internal components such as hoses and leveling rods will determine if the fiberglass components will pass dielectric testing.

This procedure is provided as guidance to be performed when a unit fails to pass a dielectric test. Dielectric testing shall only be performed by a Qualified Person following the procedures in the Service Manual and ANSI.

INTRODUCTION

Always consult your unit specific maintenance manual along with relevant standards and company policies before performing a dielectric test.



Dielectric testing shall only be performed by a Qualified Person

STEP 1

Prior to retesting, clean the boom thoroughly with a non-abrasive cleaner such as Simple Green and a Scotch Brite Pad (fine abrasive).

Inspect the interior of the boom looking at the hoses and leveling system. Clean out any debris which may remain from the original cleaning before the first test. Wash the interior surface of the boom with soap. Do not use detergents as they will remove the wax on the interior of the boom. Be careful not to apply water pressure to the hoses, it will strip the jacket off the hoses. Flush with clean water to remove any residue.

The insulated portion of the boom must be free of scars, gouges, scuff marks and wear pad marks.

Note: Never steam clean the boom.



Steam cleaning will cause water to be absorbed into the boom and damage the hoses.

STEP 2

Dry the boom out for a minimum of 24 hours in an environment with less than 25 percent humidity and a minimum temperature of 60 degrees Fahrenheit.

STEP 3

Perform the dielectric test. If the unit fails to pass the required dielectric test, verify the test equipment and test set-up before retesting again.

STEP 4

If the unit still fails to pass the dielectric test, begin removing components inside of the boom one at a time and retesting until the component causing the problem is identified.

STEP 5

If components inside the boom are identified as the cause of failure, then replace the components, refinish the boom with wax or silicone spray as specified in the unit specific maintenance manual, and perform a dielectric test before the unit goes back into service.

STEP 6

If all of the components inside the boom have been removed and the unit still fails to pass the dielectric test, then there is a problem with the fiberglass boom.

Use mirrors, or a camera, inside the boom and inspect for possible tracking, dirt or damage on the interior of the boom. If rusty or dirty areas are found, then it will require scrubbing the interior.

If tracking has burnt deep enough in the fiberglass it may require replacement.

If the boom passes after cleaning the inside, recoat the interior with silicone or wax to restore water protection. Perform a dielectric test before the unit goes back into service.

STEP 7

If the boom still hasn't passed the dielectric test, and you are using a DC Dielectric test machine, then using 100-grit sandpaper remove a 12 inch wide area of the outer boom finish completely around the boom, in the insulated section. Clean and dry the boom and then perform a dielectric test. (This only works for a DC test.)

Note: Remove only the outer paint and/or gel coat finish, do not sand into the fiberglass.

If the dielectric test fails, then the insulated boom must be replaced.

If the unit passes the dielectric test, the outer coating must be restored and the boom refinished with wax or silicone spray as specified in the unit specific maintenance manual.

Perform a dielectric test before the unit goes back into service.

STEP 8

If the boom is replaced, a qualification test must be performed before the unit goes back into service.



FOR FURTHER ASSISTANCE,
CONTACT THE TEREX UTILITIES TECHNICAL SUPPORT TEAM
PHONE: **1-844-TEREX4U (1-844-837-3948)** | EMAIL: **UTILITIES.SERVICE@TEREX.COM**
