

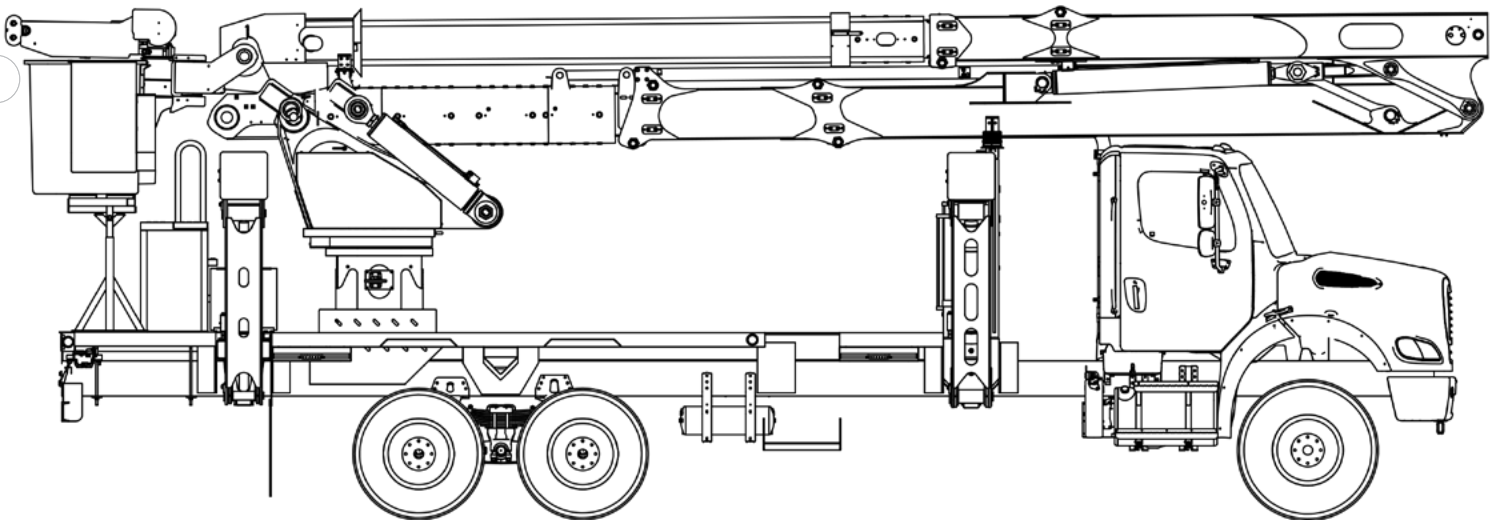

TECH TIPS

TM JIB REMOVAL

NO. 59



SERVICE CALL:
TM JIB REMOVAL



MODEL(S):
TM



TOOLS NEEDED:
LIFTING STRAPS
SIMPLE HAND TOOLS

TEREX UTILITIES TECHNICAL SUPPORT TEAM

PHONE: 1-844-TEREX4U (1-844-837-3948) | EMAIL: UTILITIES.SERVICE@TEREX.COM

! WARNING



Injection Hazard
Fluid escaping under pressure can penetrate skin and result in death or serious injury.



Relieve pressure before disconnecting hydraulic lines.
Stay clear of leaks and pin holes. Use a piece of cardboard or wood to search for leaks. Do not use hand.
Fluid injected into skin must be surgically removed within a few hours by a doctor familiar with this type of injury, or gangrene will result.



DANGER

Failure to obey the instructions and safety rules in the appropriate Operator's Manual and Service Manual for your machine will result in death or serious injury.

Many of the hazards identified in the Operator's Manual are also safety hazards when maintenance and repair procedures are performed.

DO NOT PERFORM MAINTENANCE UNLESS:

- ✓ You are trained and qualified to perform maintenance on this machine.
- ✓ You read, understand and obey:
 - manufacturer's instructions and safety rules
 - employer's safety rules and worksite regulations
 - applicable governmental regulations
- ✓ You have the appropriate tools, lifting equipment and a suitable workshop.

The information contained in this Tech Tip is a supplement to the Service Manual. Consult the appropriate Service Manual of your machine for safety rules and hazards.



TECH TIP 59 | RELEASED 08.25.2022 | VERSION 1.1
©TEREX UTILITIES. ALL RIGHTS RESERVED

CONTENTS

TECH TIP #59

4

| *Unit set-up and cover removal*

STEP 1 - STEP 2

5

| *Position the jib and remove the nut and bolt attaching the retaining ring*

STEP 3 - STEP 4

6

| *2 ways to lift the jib*

STEP 5 - STEP 8

7

| *Lifting the jib continued!*

STEP 9 - STEP 11

STEP 1

Properly set-up the unit according to the operator's manual with the unit in the ground mount position. See **Figure 1** for an example of the ground mount position.



FIGURE 1

STEP 2

Remove the cover over the back of the platform bracket. **Figure 2** shows the polytop screws holding the covers on.

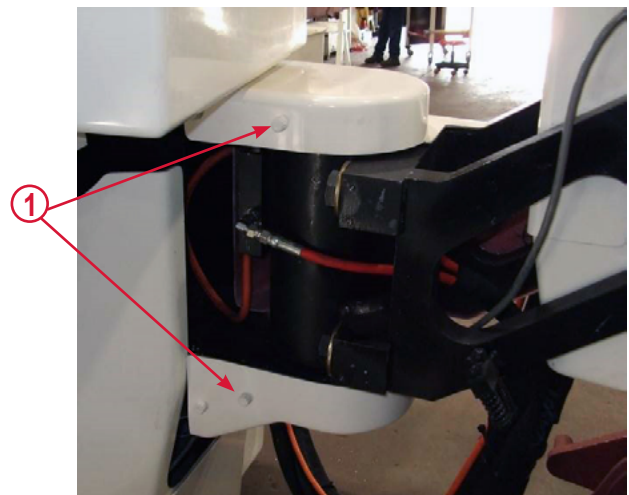

FIGURE 2

1. Polytop screws holding covers

STEP 3

Place the jib in position to be removed (consult **Step 5**). Disconnect the hoses coming down the jib pivot shaft. If equipped, disconnect the quick couplers.

If Jib is not equipped with quick couplers, then disconnect the first fitting below the pivot shaft, cap and plug all lines and connections.



FIGURE 3



Escaping fluid under pressure can penetrate skin causing serious injury.

Relieve pressure before disconnecting hydraulic lines. Keep away from leaks and pin holes. Use a piece of cardboard or paper to search for leaks. **DO NOT** use your hand.

STEP 4

Remove the nut and bolt attaching the retaining ring to the bottom of the jib pivot.

See **Figure 4** for an example of the retaining ring location.

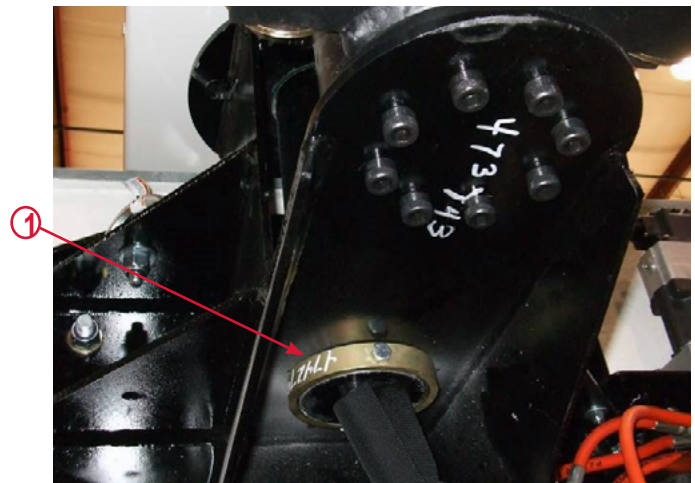

FIGURE 4

1. Retaining ring location at bottom of the jib pivot

STEP 5

The jib can be lifted in 2 ways:

1 - Step 6 explains how to use the load line and hook on the jib.

2 - Steps 7-10 explains how to use slings to lift the jib.

STEP 6

Using the jib tilt function, prior to disconnecting the hoses, fully raise the jib to its vertical position. Lift the jib using the load line and hook

See **Figure 5** for an example of this position.



FIGURE 5

STEP 7

Prior to disconnecting the hoses, fully lower the jib to its horizontal position. Fully retract both the manual jib extension and the hydraulic jib extension.

STEP 8

Remove the top sheave from the jib and place it in one eye of a 4-foot eye and eye web sling.

See **Figure 6** for an example of this step.

Reinstall the sheave in the sheave head.



FIGURE 6

STEP 9

Connect a 5-foot eye and eye web sling around the winch drum using a choker hitch.

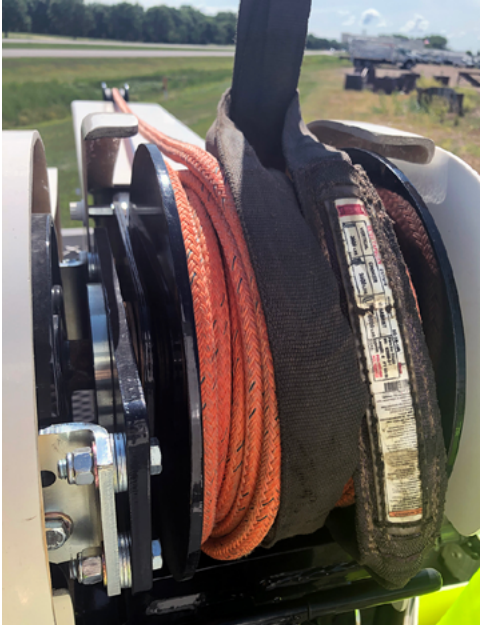

STEP 10

Connect the free ends of the web slings by placing both eyes in a shackle. Lift the assembly from the shackle.



STEP 11

Place the jib assembly on adequate supports in a suitable work area.



If the jib is not re-installed prior to using the machine, then a non-conductive cover **MUST** be installed to cover the conductive components exposed from removing the jib. **P/N: 606181**



FOR FURTHER ASSISTANCE,
CONTACT THE TEREX UTILITIES TECHNICAL SUPPORT TEAM
PHONE: **1-844-TEREX4U (1-844-837-3948)** | EMAIL: **UTILITIES.SERVICE@TEREX.COM**
