

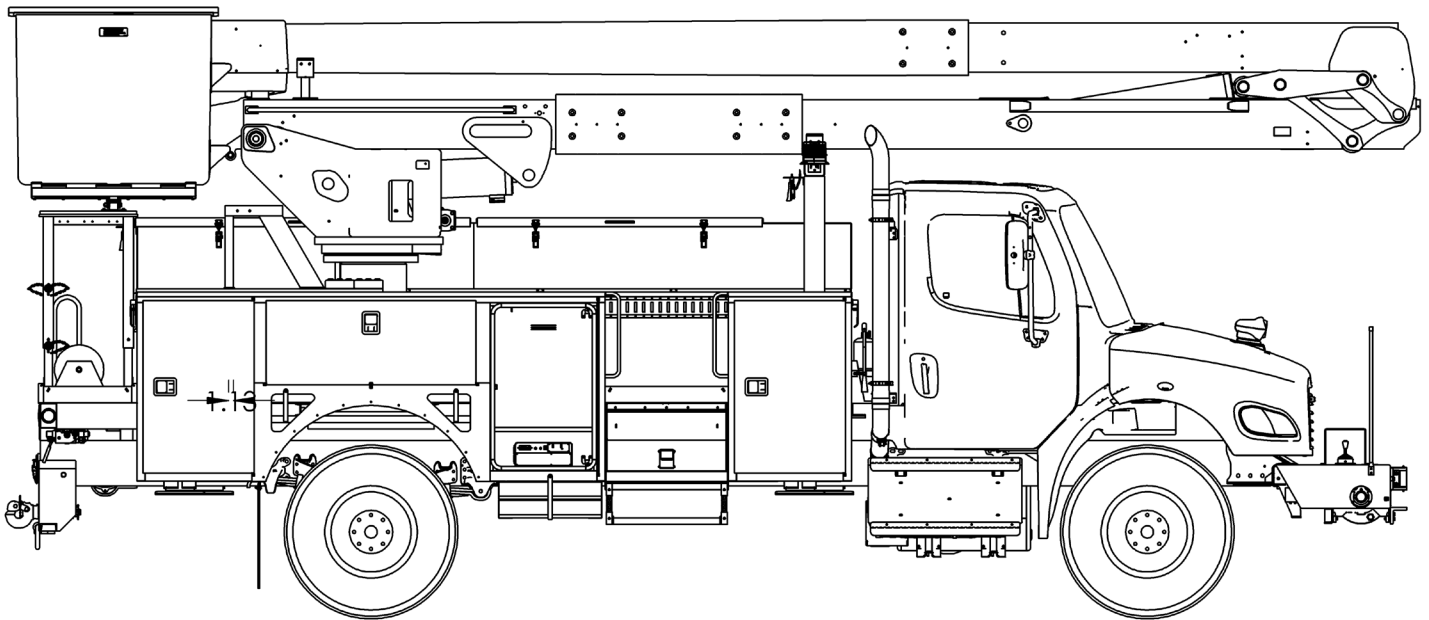

TECH TIPS

TROUBLESHOOTING THE LEVELING GENERATOR

NO. 63



SERVICE CALL:
TROUBLESHOOTING THE
LEVELING GENERATOR



MODEL(S):
TM



TOOLS NEEDED:
MULTIMETER
1/2" 12-POINT WRENCH OR
SOCKET
MEDIUM BLADE FLAT
SCREWDRIVER

TEREX UTILITIES TECHNICAL SUPPORT TEAM

PHONE: 1-844-TEREX4U (1-844-837-3948) | EMAIL: UTILITIES.SERVICE@TEREX.COM

! WARNING



Injection Hazard
Fluid escaping under pressure can penetrate skin and result in death or serious injury.

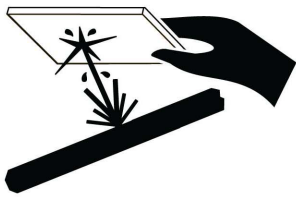

Relieve pressure before disconnecting hydraulic lines.
Stay clear of leaks and pin holes. Use a piece of cardboard or wood to search for leaks. Do not use hand.
Fluid injected into skin must be surgically removed within a few hours by a doctor familiar with this type of injury, or gangrene will result.



DANGER

Failure to obey the instructions and safety rules in the appropriate Operator's Manual and Service Manual for your machine will result in death or serious injury.

Many of the hazards identified in the Operator's Manual are also safety hazards when maintenance and repair procedures are performed.

DO NOT PERFORM MAINTENANCE UNLESS:

- ✓ You are trained and qualified to perform maintenance on this machine.
- ✓ You read, understand and obey:
 - manufacturer's instructions and safety rules
 - employer's safety rules and worksite regulations
 - applicable governmental regulations
- ✓ You have the appropriate tools, lifting equipment and a suitable workshop.

The information contained in this Tech Tip is a supplement to the Service Manual. Consult the appropriate Service Manual of your machine for safety rules and hazards.



TECH TIP 63 | RELEASED 08.30.2022 | VERSION 1.0
©TEREX UTILITIES. ALL RIGHTS RESERVED

CONTENTS

TECH TIP#63

TOC

4

| Check battery

STEP 1 - STEP 2

5

| Check pressure switches

STEP 3

6

| Check the weather pack

STEP 3 - STEP 5

7

| Check continuity

STEP 6 - STEP 7

8

| Check voltage

STEP 8 - STEP 9

9

| Check connections

STEP 10 - STEP 11

STEP 1

Remove the fiberglass covers over the platform leveling control box located below the servo valve and the bracket cover located below the jib/winch assembly.

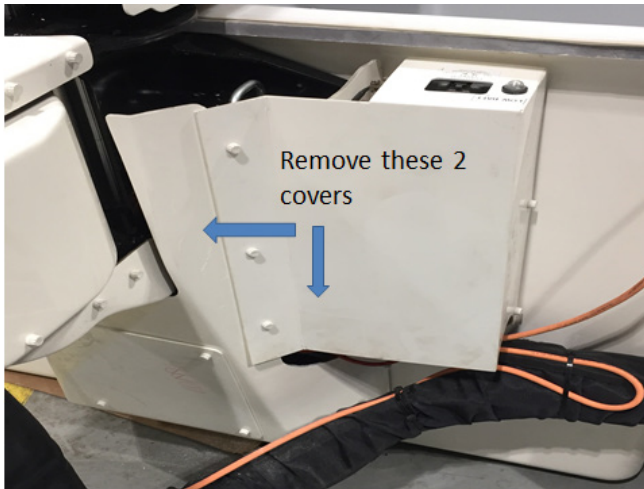

FIGURE 1



FIGURE 2

STEP 2

Inside the level control box is the 12v 1.5-amp battery. The battery must have greater than 6 volts in the battery to excite the voltage regulator to allow it to charge. If the battery has less than 6 volts, charge or replace the battery by using a battery charger set at 2 amps. The 12v battery is only 1.5 amps.

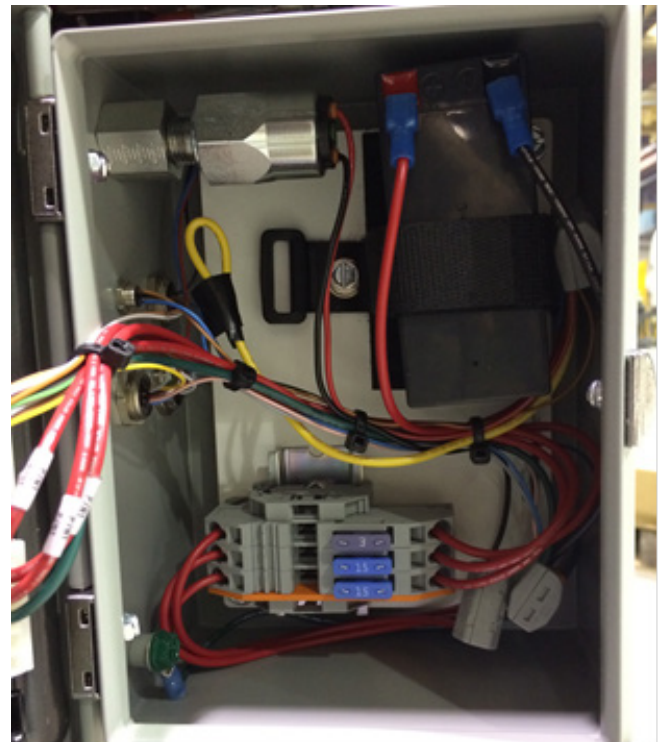

FIGURE 3

STEP 3

Check both pressure switches to make sure that they are open with the unit not running. One pressure switch is located in the battery/control box and the other is located on the generator assembly.

To check the pressure switches, use your volt meter with the ohms setting to check continuity.

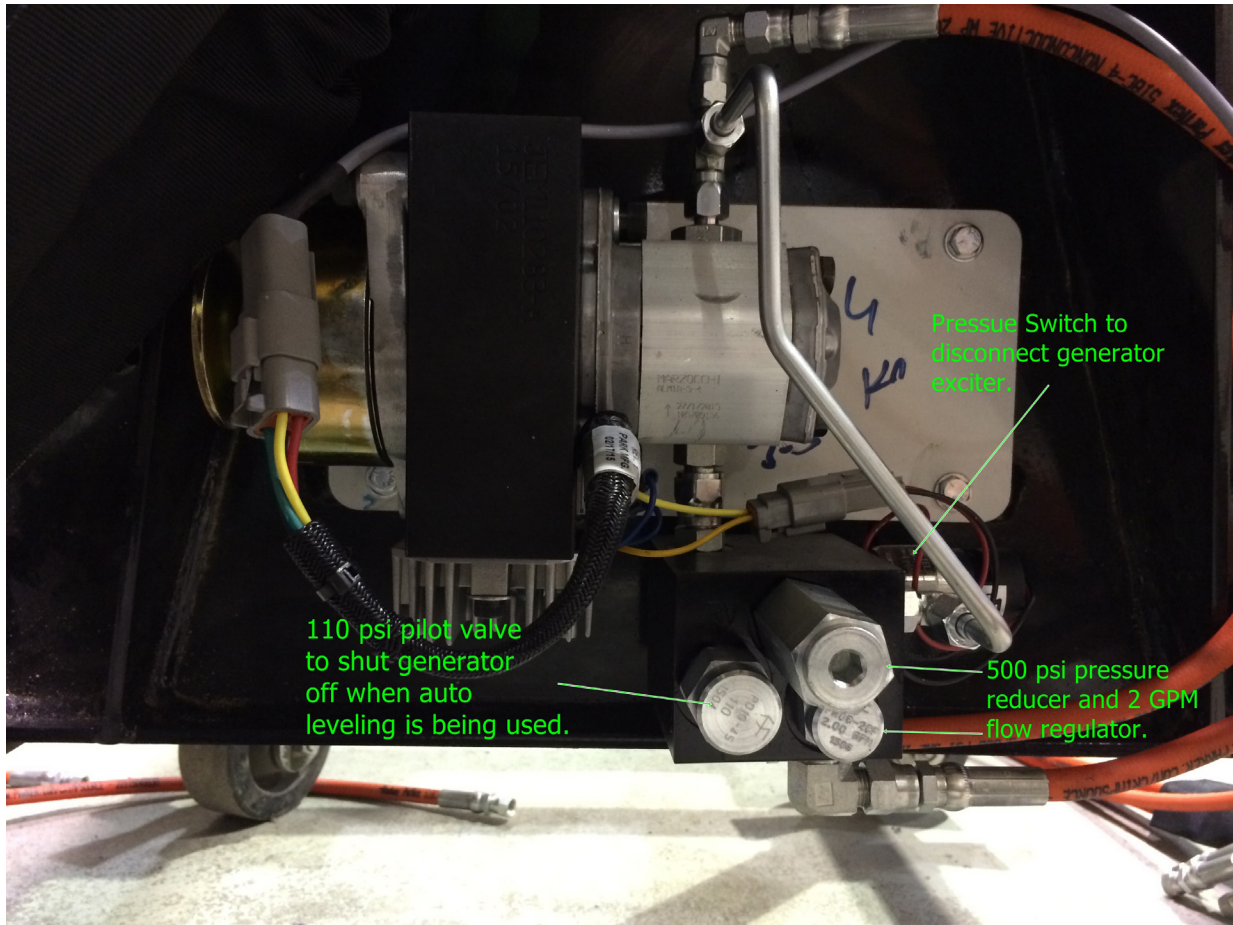

FIGURE 4

STEP 3 (Continued)

Unplug the weather pack connector on the pressure switch on the generator and check the wires coming out of the pressure switch in the control box. See above picture of the generator to find the pressure switch and weather pack plug.

The wires can be unhooked on the quick connects by lifting up on the arm and removing the wire, located in the control box.

There should be no reading, if it shows any reading the pressure switch is defective and is causing the battery to drain down and it should be replaced.

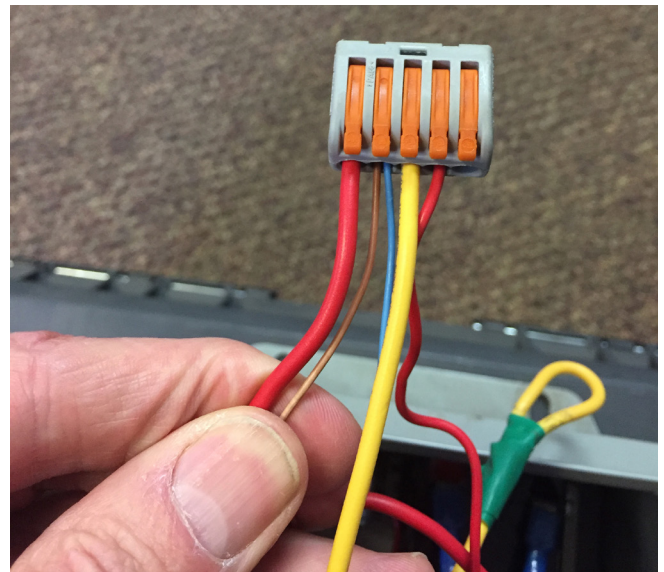

FIGURE 4

STEP 4

If the pressure switches are operational then check for voltage at the weather pack plug at the generator going to the voltage regulator.

STEP 5

Disconnect the weather pack and check for battery voltage on the blue and brown wires, using the black wire for ground, coming from the leveling control box marked generator on the control box. Both wires should have battery voltage. If one or both wires do not show voltage, troubleshoot and repair wires as needed. This connector is located at the generator assembly. **Figure 5-7**

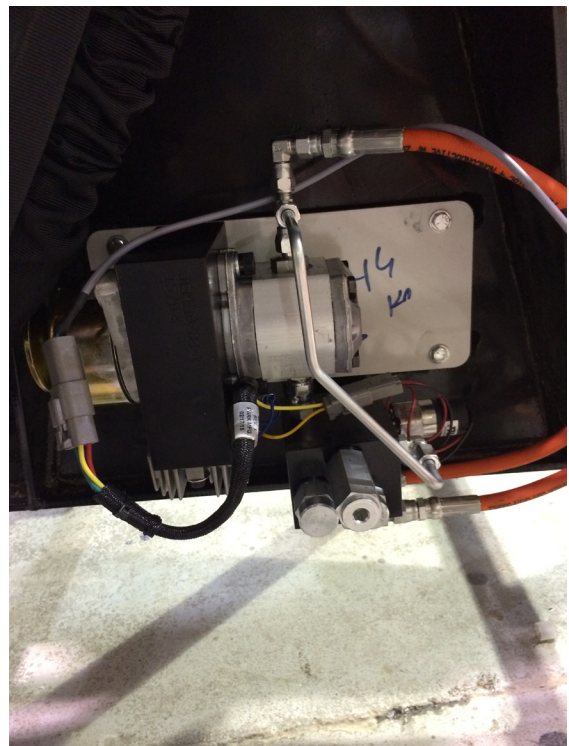

FIGURE 5



FIGURE 6



FIGURE 7

STEP 6

Plug weather pack back up and check for voltage on the back side of the plug. The blue wire should connect to the yellow wire, the brown wire should connect to the red wire and the black wire goes to the black wire.

If the wires do not match up correctly, move and repair as needed. The wires are very small and can break easily.

STEP 7

With the unit running make sure that the pressure switch at the generator is closed while the generator is running and pressure switch unplugged. Use the voltmeter in Ohms to check continuity through the pressure switch only. If it doesn't, try adjusting the allen screw in the

middle of the pressure switch out to decrease pressure. If you can adjust it so that it comes "on" then shut unit down to make sure the pressure switch opens back up when generator isn't running.

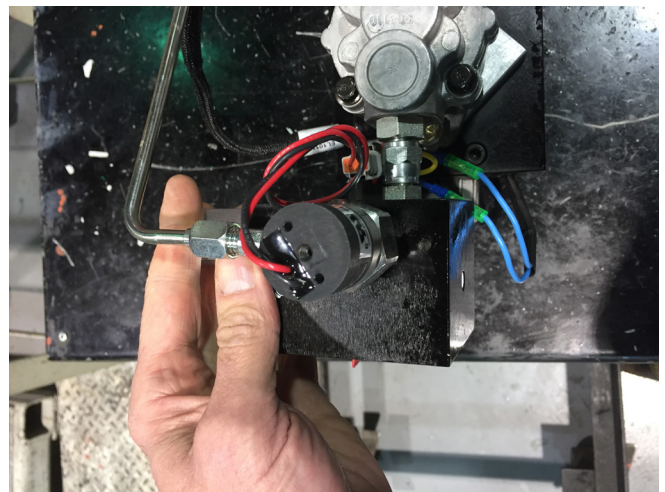

FIGURE 8

STEP 8

If everything checks out remove the brown wire from the quick disconnect in the control box that is coming from the bulkhead with the blue wire and check for voltage.

The voltage reading should be 13-13.5 volts. This is the voltage coming out of the voltage regulator to charge the battery. If you have this voltage plug the brown wire back in to make sure the voltage stays the same. If the voltage drops down, go back to the weather pack plug and check the voltage on the red wire. If voltage is at the 13-13.5, then repair the connector on the brown wire on the weather pack connector coming from the leveling control box. **Figure 9 and 10**

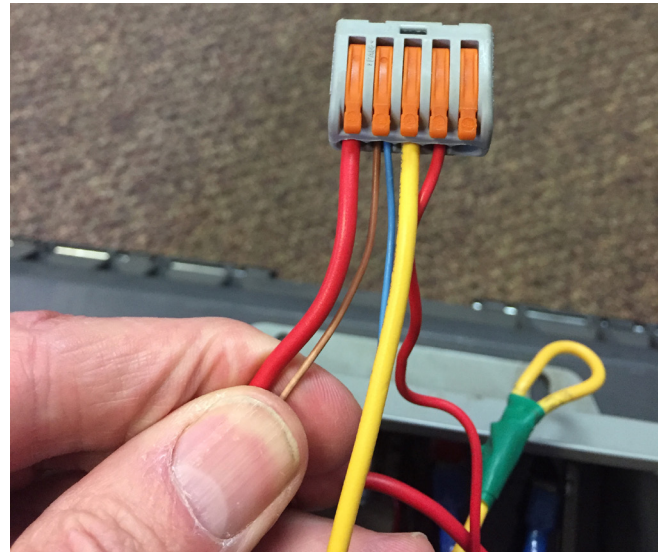

FIGURE 9

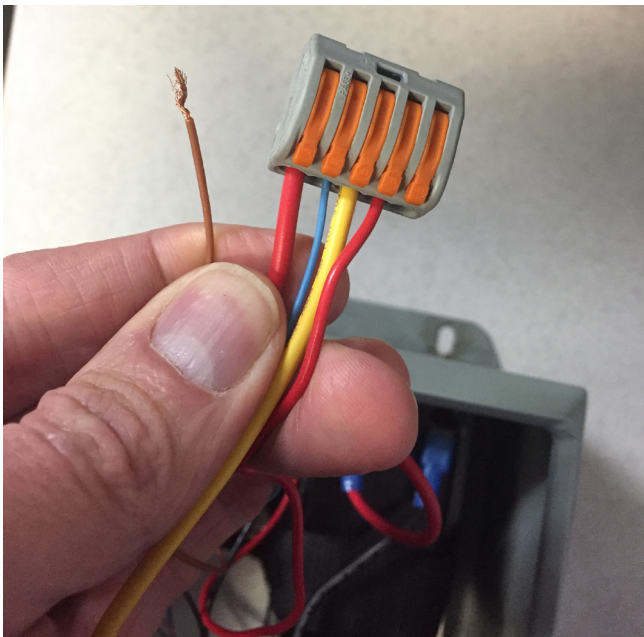

FIGURE 10

STEP 9

If the voltage is around the 11 to 12.5 volts on the brown wire when testing in step 8 the flow control in the generator manifold needs to be increased to 2.5 GPM's. Order a new flow regulator, part number 615717.

STEP 10

If voltage is coming into the weather pack connector from the leveling control box on both sides and the pressure switch at the generator manifold is good, but no voltage is coming out or no ground signal is coming from the voltage regulator. Then check the butt connectors between the weather pack connector and the voltage regulator to make sure that it didn't come a part. Repair as needed.

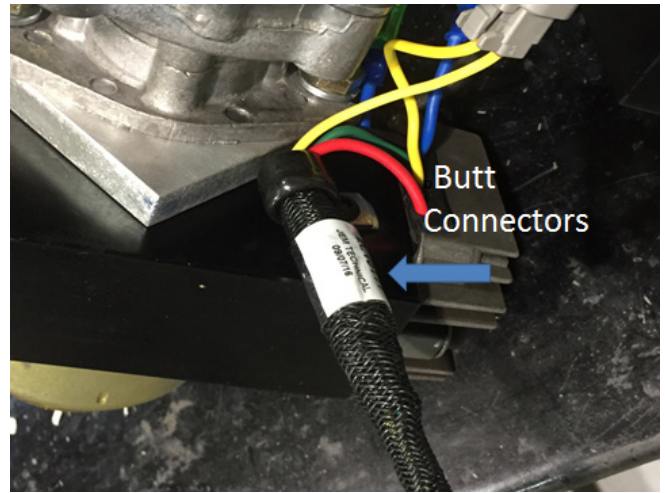

FIGURE 11

STEP 11

If everything in the previous steps is correct but the generator isn't putting out any voltage, then replace the generator.



FOR FURTHER ASSISTANCE,
CONTACT THE TEREX UTILITIES TECHNICAL SUPPORT TEAM
PHONE: **1-844-TEREX4U (1-844-837-3948)** | EMAIL: **UTILITIES.SERVICE@TEREX.COM**
