

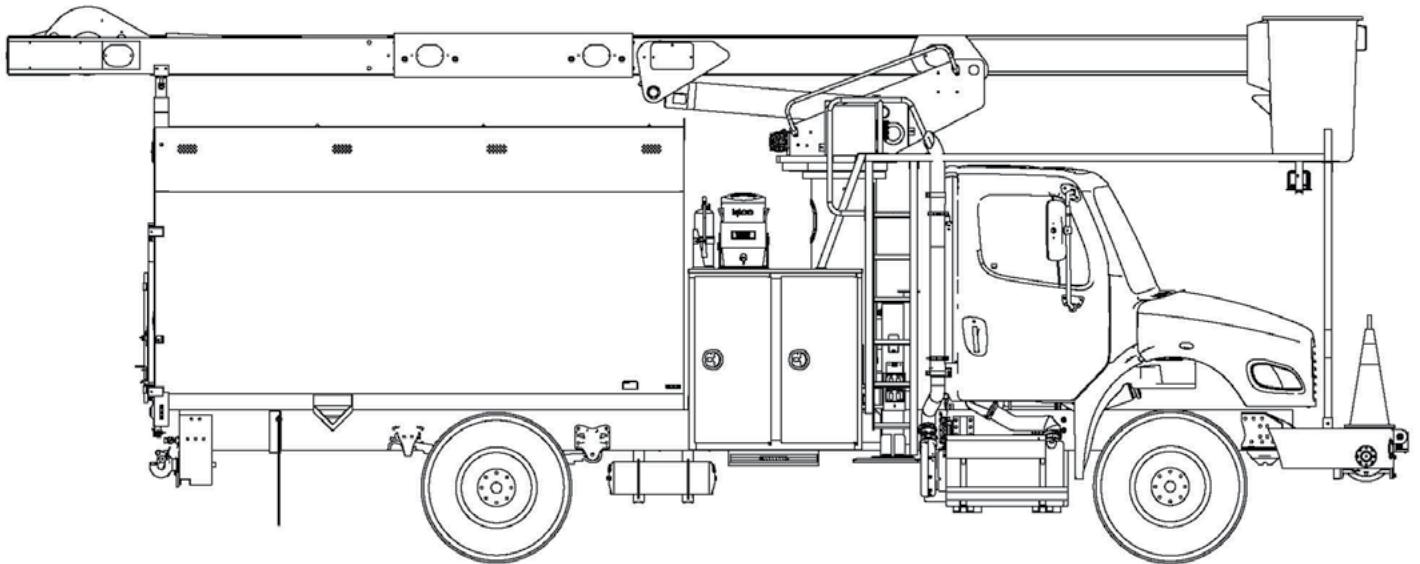

TECH TIPS

INSPECTING THE PLATFORM LEVELING SYSTEM AFTER CONTACT/DAMAGE

NO. 66



SERVICE CALL:
INSPECTING THE PLATFORM
LEVELING SYSTEM AFTER
CONTACT / DAMAGE



MODEL(S):
XT AND XT PRO



TOOLS NEEDED:
OPEN END WRENCHES
SOCKETS UP TO 1 INCH
SPECIALTY TOOL - SEE
INTRODUCTION

TEREX UTILITIES TECHNICAL SUPPORT TEAM

PHONE: 1-844-TEREX4U (1-844-837-3948) | EMAIL: UTILITIES.SERVICE@TEREX.COM



DANGER

Failure to obey the instructions and safety rules in the appropriate Operator's Manual and Service Manual for your machine will result in death or serious injury.

Many of the hazards identified in the Operator's Manual are also safety hazards when maintenance and repair procedures are performed.

DO NOT PERFORM MAINTENANCE UNLESS:

- ✓ You are trained and qualified to perform maintenance on this machine.
- ✓ You read, understand and obey:
 - manufacturer's instructions and safety rules
 - employer's safety rules and worksite regulations
 - applicable governmental regulations
- ✓ You have the appropriate tools, lifting equipment and a suitable workshop.

The information contained in this Tech Tip is a supplement to the Service Manual. Consult the appropriate Service Manual of your machine for safety rules and hazards.



TECH TIP 66 | RELEASED 09.06.2022 | VERSION 1.0
©TEREX UTILITIES. ALL RIGHTS RESERVED

CONTENTS

TECH TIP#66

TOC

4

| *Specialty Tool*

INTRODUCTION

5

| *Support the platform*

| *Unscrew tumbuckle*

STEP 1 - STEP 2

6

| *Remove the chains*

| *Inspect chains*

STEP 3 - STEP 5

INTRODUCTION

If the platform is out of level on an XT or XT Pro unit, there is a strong possibility that the platform has made contact with a fixed object.

When the platform makes contact with a fixed object the leveling system can be damaged or the chain can jump timing, which in turn will cause the platform to go out of level.

If the platform has made contact and knocked the leveling out of timing, all the components of the leveling system must be removed, inspected, repaired, and reinstalled as necessary.

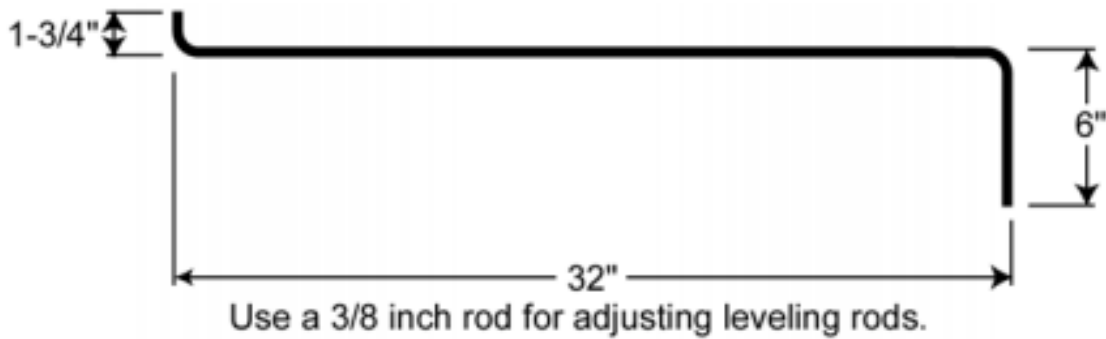
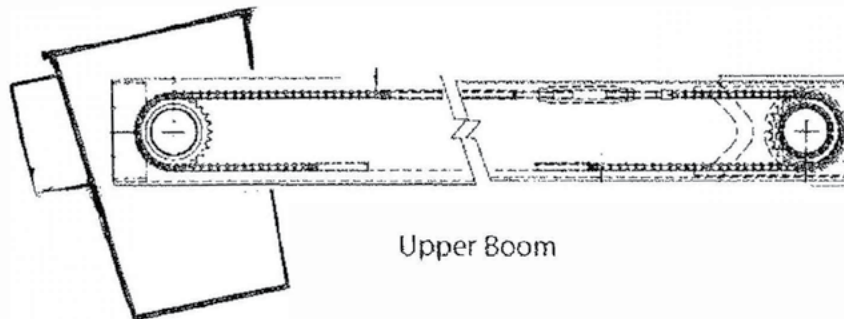

FIGURE 1 - Specialty Tool



If the chains are not timed properly, the rod terminals will ride up on the sprocket. This puts undue strain on the system and may cause damage. Failure of the leveling systems may cause the platform to upset and eject the operator, causing death or serious injury.



STEP 1

Before removal, the platform must be supported by a suitable lifting device to prevent movement.

STEP 2

Loosen the locknut securing the turnbuckle. The turnbuckles are located near the turntable in the lower boom and near the elbow in the upper boom. Unscrew the turnbuckle fully.

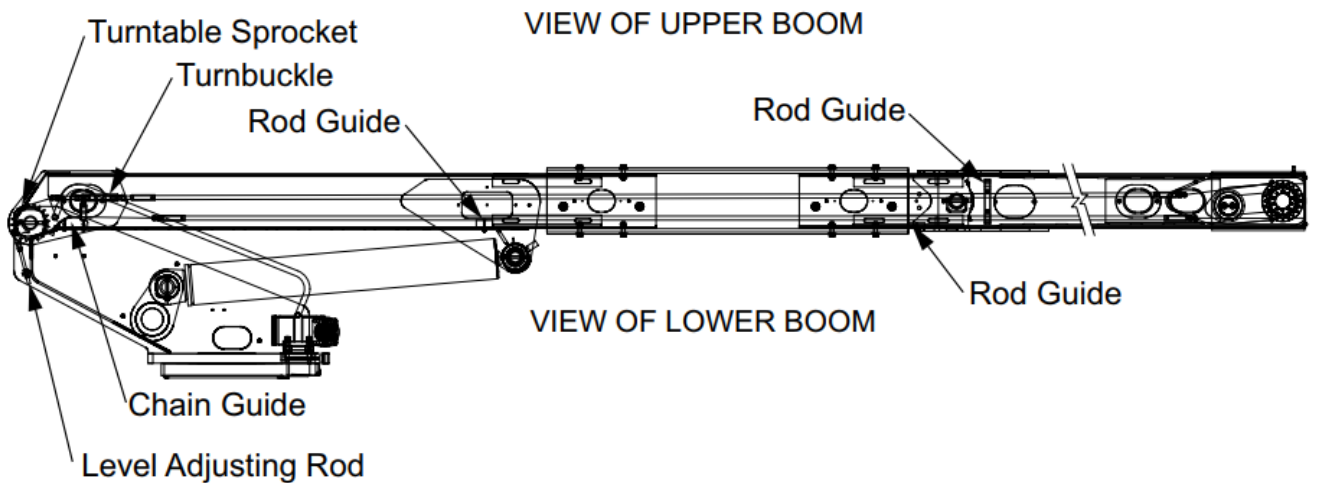
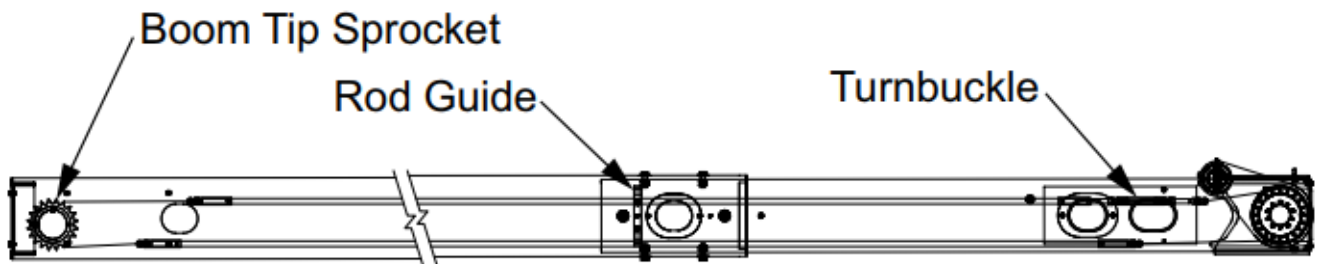

STEP 3

Pull the chains with the rods attached out the elbow end of the lower boom and the platform end of the upper boom. Place in a suitable work area.



STEP 4

Inspect the chains following the chain inspection procedure. Inspect fiberglass rods and rod terminal for slippage. The master link must be properly installed and the cotter keys cannot be deformed or sheared. If the master link is retained with a clip, it must be in place.

STEP 5

Repair or replace any damaged components. Install the leveling system according to your unit specific maintenance manual. After installing the chains as directed in the manuals adjust the leveling with the Leveling Adjusting Rod, this includes units equipped with hydraulic tilt.

Note that hydraulic tilt will not adjust the platform to level after reinstalling the rods and chains. Hydraulic tilt is only meant to dump the platform.



FOR FURTHER ASSISTANCE,
CONTACT THE TEREX UTILITIES TECHNICAL SUPPORT TEAM
PHONE: **1-844-TEREX4U (1-844-837-3948)** | EMAIL: **UTILITIES.SERVICE@TEREX.COM**
