

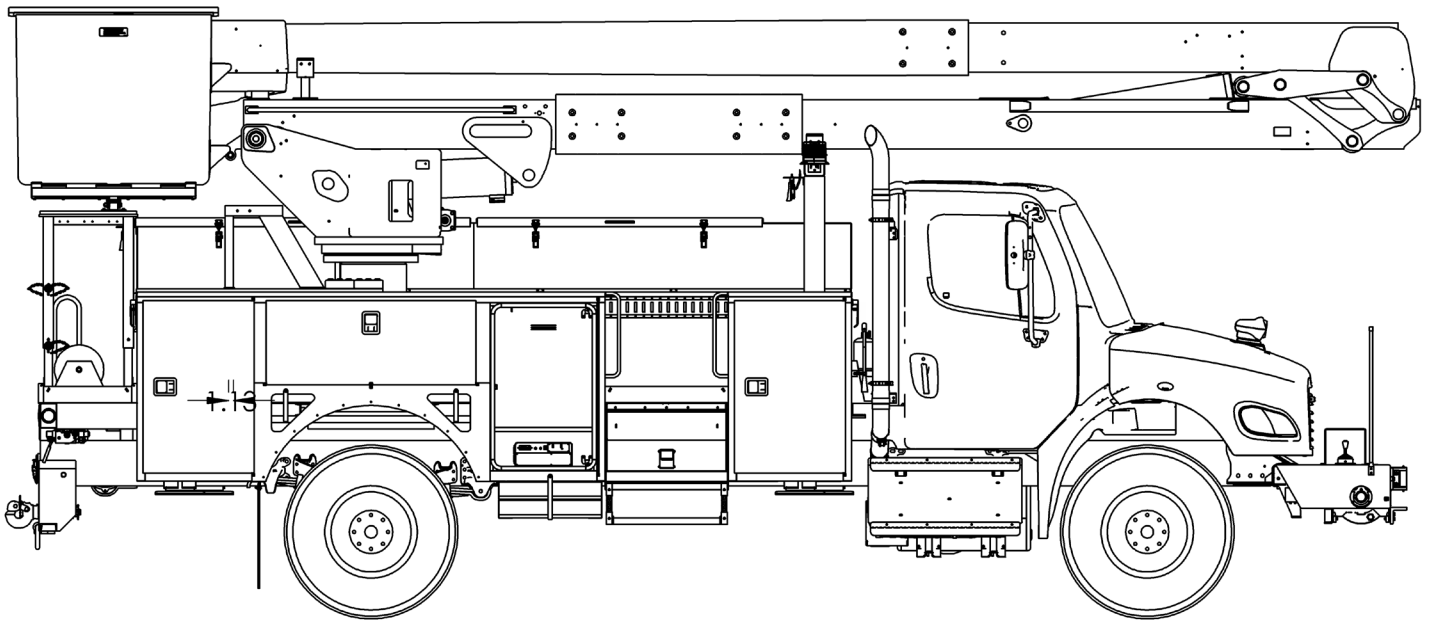

TECH TIPS

ADJUSTING BOOM OVER-STOW PROTECTION ON AN AERIAL DEVICE

NO. 06



SERVICE CALL:
ADJUSTING BOOM OVER-STOW
PROTECTION ON AN AERIAL
DEVICE



MODEL(S):
HR, HRX, SC, SCM, XT, XT PRO, TC,
TCX, RM, RMX, TM, LT, LTM, TL,
L13I, TL17I



TOOLS NEEDED:
3/4" WRENCH
1/4" ALLEN WRENCH

TEREX UTILITIES TECHNICAL SUPPORT TEAM

PHONE: 1-844-TEREX4U (1-844-837-3948) | EMAIL: UTILITIES.SERVICE@TEREX.COM



DANGER

Failure to obey the instructions and safety rules in the appropriate Operator's Manual and Service Manual for your machine will result in death or serious injury.

Many of the hazards identified in the Operator's Manual are also safety hazards when maintenance and repair procedures are performed.

DO NOT PERFORM MAINTENANCE UNLESS:

- ✓ You are trained and qualified to perform maintenance on this machine.
- ✓ You read, understand and obey:
 - manufacturer's instructions and safety rules
 - employer's safety rules and worksite regulations
 - applicable governmental regulations
- ✓ You have the appropriate tools, lifting equipment and a suitable workshop.

The information contained in this Tech Tip is a supplement to the Service Manual. Consult the appropriate Service Manual of your machine for safety rules and hazards.



TECH TIP 06 | RELEASED 02.08.2022 | VERSION 1.0
©TEREX UTILITIES. ALL RIGHTS RESERVED

CONTENTS

TECH TIP#06

TOC

4

INTRODUCTION

5

| *Locate boom over-stow protection valve*
| *Verify operation.*

STEP 1 - STEP 2

6

| *Adjust the boom over-stow valve*

STEP 3 - STEP 5

INTRODUCTION

The boom over-stow system is used to limit the amount of down pressure that the lower boom can put into the rest. This is accomplished by opening a solenoid valve that allows boom down oil over a relief that is set lower than system pressure. The solenoid valve is enabled by a switch positioned at the lower boom rest.

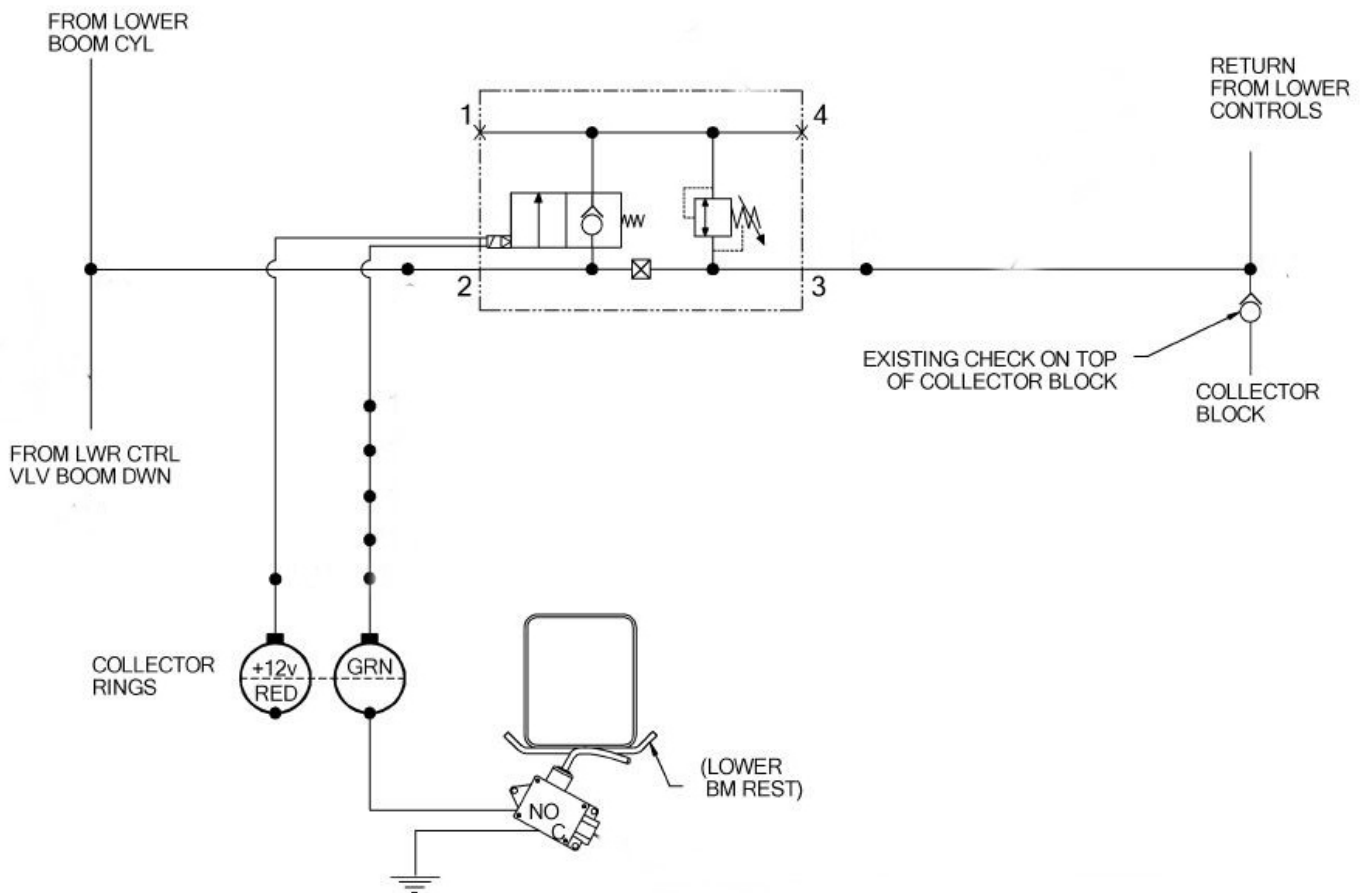

STEP 1

Locate the Boom Over-Stow Protection Valve teed into the boom down hydraulic circuit. The valve is typically located above rotation inside the turret near the lower control valve.



STEP 2

To check that the boom stow protection is working properly:

- Verify that the oil temperature is at least 90 degrees Fahrenheit
- If equipped with a manual 2-speed, turn on high throttle
- Position the lower boom five feet out of the rest
- Activate and hold the lower boom over-stow switch with a zip tie and move the lower boom down towards the rest
- The boom should take 5 ± 2 seconds to reach the boom rest
- The boom must apply adequate pressure to keep the boom from bouncing in the rest during road travel

If boom will not descend or descends slower than the time allowed go to Step 3, if boom descends faster than the time allowed go to Step 4.

STEP 3

If boom will not descend or descends too slowly:

- Locate the boom over-stow valve
- Loosen 3/4" locknut and turn the Allen adjustment in until the system operates as outlined in Step 2.

STEP 4

If the boom descends too quickly:

- Locate the boom over-stow valve
- Loosen 3/4" locknut and turn the Allen adjustment out until the system operates as outlined in Step 2

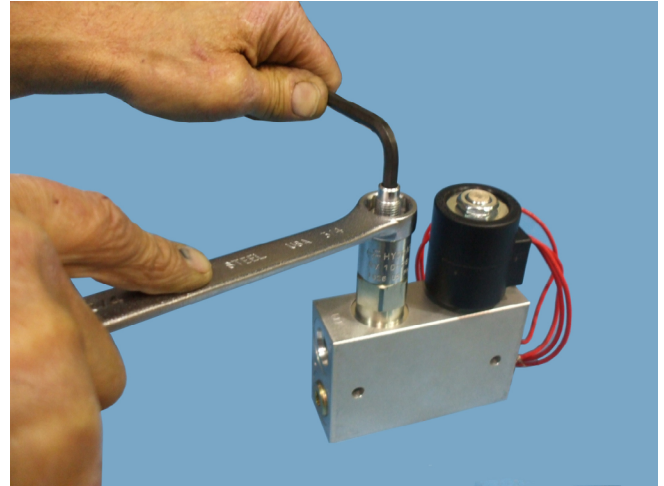

STEP 5

Once the adjustment is correct, tighten the 3/4" locknut while holding the Allen adjustment and repeat Step 2 to verify that the adjustments have not changed.



FOR FURTHER ASSISTANCE,
CONTACT THE TEREX UTILITIES TECHNICAL SUPPORT TEAM
PHONE: [1-844-TEREX4U \(1-844-837-3948\)](tel:1-844-TEREX4U) | EMAIL: UTILITIES.SERVICE@TEREX.COM
